

# PURE

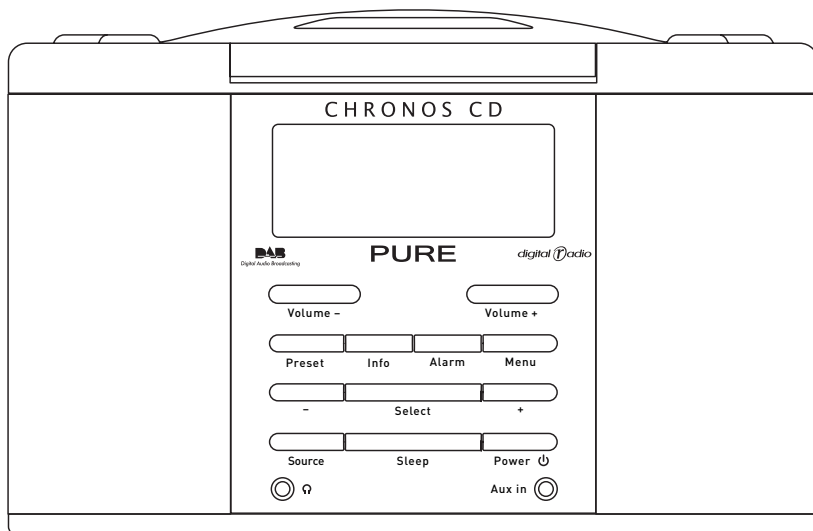

**Owner's manual**

# CHRONOS CD

## ⚠ Safety instructions

Keep the radio away from heat sources.  
Do not use the radio near water.  
Avoid objects or liquids getting into the radio.  
Do not remove screws from or open the radio casing.  
Fit the mains adaptor to an easily accessible socket,  
located near the radio and ONLY use the mains power  
adaptor supplied.

## ⚠ Sicherheitshinweise

Halten Sie das Radio fern von Heizkörpern.  
Benutzen Sie das Radio nicht in der Nähe von Wasser.  
Verhindern Sie, dass Gegenstände oder Flüssigkeiten  
in das Radio gelangen.  
Entfernen Sie keine Schrauben vom Gehäuse und  
öffnen Sie dieses nicht.  
Schließen Sie das Netzteil an eine leicht erreichbare  
Steckdose in der Nähe des Radios an, und benutzen  
Sie AUSSCHLIESSLICH das mitgelieferte Netzteil.

## ⚠ Consignes de sécurité

Tenir la radio éloignée de toute source de chaleur.  
Ne pas utiliser la radio à proximité d'un point d'eau.  
Éviter que des objets ou des liquides ne pénètrent à  
l'intérieur de la radio.  
Ne pas ouvrir le boîtier de la radio ou en enlever  
les vis.  
Branchez l'adaptateur sur une prise de courant  
facilement accessible, à proximité de la radio et  
utilisez UNIQUEMENT l'adaptateur fourni.

## ⚠ Istruzioni di sicurezza

Tenere la radio lontana da fonti di calore.  
Non utilizzare la radio vicino all'acqua.  
Evitare che oggetti o liquidi penetrino nella radio.  
Non rimuovere le viti né aprire l'involucro della radio.  
Collegare l'adattatore di rete ad una presa della  
corrente facilmente accessibile, situata vicino alla  
radio e utilizzare ESCLUSIVAMENTE l'adattatore di  
rete fornito.

## ⚠ Sikkerhedsforskrifter

Hold radioen på afstand af varmekilder.  
Brug ikke radioen i nærheden af vand.  
Undgå at der kommer genstande eller væske i radioen.  
Fjern ikke skrue fra og åbn ikke radiokabinettet.  
De bør tilslutte strømforsyningen til et lettilgængeligt  
strømdug tæt på radioen. De bør KUN bruge den  
medfølgende strømforsyning.

## ⚠ Veiligheidsinstructies

Houd de radio uit de buurt van warmtebronnen.  
Gebruik de radio niet in de buurt van water.  
Vermijd dat voorwerpen of vloeistoffen in de radio  
terechtkomen.  
Verwijder geen schroeven uit de omkasting van de  
radio en open het niet.  
Steek de lichtnetadapter in een gemakkelijk  
toegankelijk stopcontact in de buurt van de radio en  
gebruik ALLEEN de meegeleverde spanningsadapter  
voor het lichtnet.

## Copyright

Copyright 2006 by Imagination Technologies Limited.  
All rights reserved. No part of this publication may be  
copied or distributed, transmitted, transcribed, stored  
in a retrieval system, or translated into any human  
or computer language, in any form or by any means,  
electronic, mechanical, magnetic, manual or otherwise,  
or disclosed to third parties without the express written  
permission of Imagination Technologies Limited.

## Copyright

Copyright 2006 by Imagination Technologies Limited.  
Alle Rechte vorbehalten. Kein Teil dieser Publikation  
darf ohne ausdrückliche und schriftliche Zustimmung  
von Imagination Technologies Limited in irgendeiner  
Form (elektronisch, mechanisch, magnetisch, manuell  
oder auf andere Weise) kopiert, verteilt, übermittelt,  
überschrieben, in einem Suchsystem gespeichert,  
in eine andere natürliche oder Computersprache  
übersetzt oder Dritten zugänglich gemacht werden.

## Copyright

Copyright 2006 Imagination Technologies Limited.  
Tous droits réservés. Aucune partie de la présente  
publication ne doit être copiée ou diffusée, transmise,  
retranscrite, stockée dans un système de récupération  
de données ou traduite, que ce soit dans une langue  
humaine ou dans un langage informatique, sous  
quelque forme et par quelque moyen que ce soit,  
électronique, mécanique, magnétique, manuel ou autre,  
ou encore diffusée auprès de tiers sans autorisation  
écrite expresse de Imagination Technologies Limited.

## Copyright

Copyright 2006 by Imagination Technologies Limited.  
Tutti i diritti riservati. Nessuna parte della presente  
pubblicazione può essere copiata o distribuita,  
trasmessa, trascritta, memorizzata in un sistema di  
archiviazione, o tradotta in un formato normalmente  
comprensibile, in qualsiasi forma o con qualsiasi  
mezzo, elettronico, meccanico, magnetico, manuale  
o altro, o divulgata a terze parti senza il permesso  
scritto di Imagination Technologies Limited.

## Copyright

Copyright 2006 tilhører Imagination Technologies  
Limited. Alle rettigheder forbeholdes. Ingen dele af  
denne publikation må kopieres eller distribueres,  
transmitteres, omskrives, gemmes i et system, hvor den  
kan hentes, eller oversættes til menneskeligt forståeligt  
sprog eller computersprog, i nogen som helst form eller  
med nogen som helst midler, det være sig elektroniske,  
mekaniske, magnetiske, manuelle eller på anden  
måde, eller fremvises til tredje parter uden udtrykkelig,  
skriftlig tilladelse fra Imagination Technologies Limited.

## Copyright

Copyright 2006 door Imagination Technologies Limited.  
Alle rechten gereserveerd. Geen enkel gedeelte van  
deze publicatie mag gekopieerd of gedistribueerd,  
uitgezonden, overgeschreven, opgeslagen in een  
retrieval system of vertaald in om het even welke  
menselijke of computertaal, in geen enkele vorm of  
door geen enkel middel, elektronisch, mechanisch,  
magnetisch, manueel of anders of bekend gemaakt  
aan derde partijen zonder de uitdrukkelijke geschreven  
toestemming van Imagination Technologies Limited.

## Trademarks

CHRONOS, textSCAN, PURE, the PURE logo, PURE Digital,  
the PURE Digital logo, Imagination Technologies, and  
the Imagination Technologies logo are trademarks or  
registered trademarks of Imagination Technologies  
Limited. All other product names are trademarks of  
their respective companies. Version 2 August 2006.

## Warenzeichen

CHRONOS, textSCAN, PURE, das PURE Logo, PURE Digital,  
das PURE Digital Logo, Imagination Technologies und das  
Imagination Technologies Logo sind Warenzeichen oder  
eingetragene Warenzeichen von Imagination Technologies  
Limited. Alle anderen Produktnamen sind Warenzeichen  
ihrer jeweiligen Besitzer. Version 02. August 2006

## Marques commerciales

CHRONOS, textSCAN, PURE, le logo PURE, PURE  
Digital, le logo PURE Digital, Imagination Technologies  
et le logo Imagination Technologies sont des marques  
commerciales ou des marques déposées de Imagination  
Technologies Limited. Tous les autres noms de  
produits sont des marques commerciales de leurs  
détenteurs respectifs. Version 2 er août 2006.

## Marchi

CHRONOS, textSCAN, PURE, il logo PURE, PURE Digital,  
il logo PURE Digital, Imagination Technologies e il  
logo Imagination Technologies sono marchi o marchi  
registrati di Imagination Technologies Limited. Tutti  
gli altri nomi di prodotti sono marchi di proprietà  
delle rispettive società. Versione 2 agosto 2006.

## Varemærker

CHRONOS, textSCAN, PURE, PURE-logoet, PURE  
Digital, PURE Digital-logoet, Imagination  
Technologies og Imagination Technologies-logoet  
er varemærker eller registrerede varemærker, der  
tilhører Imagination Technologies Limited. Alle andre  
produktnavne er varemærker, der tilhører deres  
respektive virksomheder. Version 2. august 2006.

## Handelsmerken

CHRONOS, textSCAN, PURE, het PURE logo,  
PURE Digital, het PURE Digital logo, Imagination  
Technologies en het Imagination Technologies logo  
zijn handelsmerken of geregistreerde handelsmerken  
van Imagination Technologies Limited. Alle andere  
productnamen zijn handelsmerken van hun  
respektieve firma's. Versie 2 augustus 2006.

# Contents

<b>Overview of the controls and connectors .....</b>	<b>2</b>
<b>Overview of the display .....</b>	<b>2</b>
<b>Getting started .....</b>	<b>4</b>
<b>Using your CHRONOS CD .....</b>	<b>5</b>
Switching between DAB,FM, CD (&MP3), AUX .....	5
Changing stations.....	5
Changing the information shown on screen.....	5
textSCAN™ - pause and control scrolling text (DAB & FM) .....	6
Setting and selecting presets .....	6
Playing a CD .....	7
Using the alarms.....	8
Using the sleep timer .....	8
<b>Changing your radio setup.....</b>	<b>9</b>
DAB only options .....	9
FM only options .....	9
CD only options.....	9
General options.....	10
<b>Hints and Tips .....</b>	<b>11</b>
<b>Technical Specifications .....</b>	<b>11</b>

# Overview of the controls and connectors

## Front

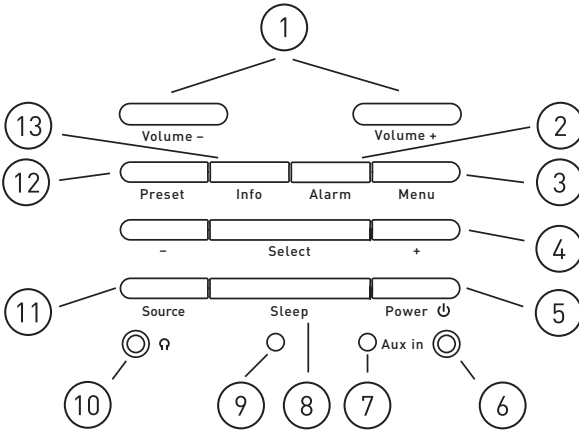

## Remote

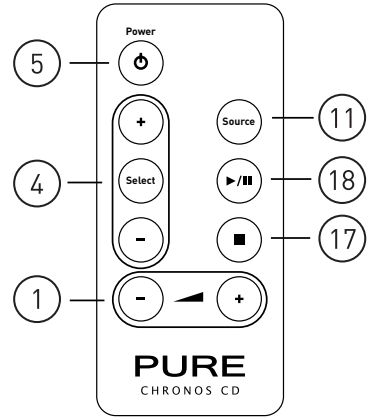

## Top

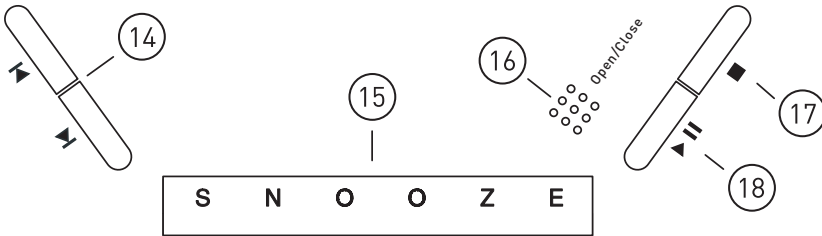

## Base

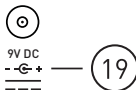

# Overview of the display

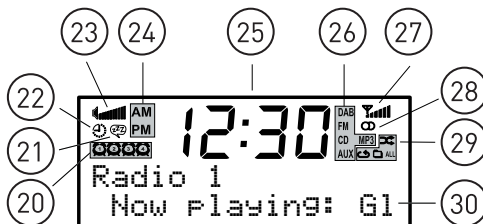

1. Volume control.
2. Adjust and set alarms while your unit is switched on or in standby.
3. Access setup options.
4. DAB +/- scroll radio stations or menu options and Select to confirm.  
FM +/- press and release to manually step up or down frequency range. Hold and release to scan to next station.  
CD (on remote only) +/- press to skip tracks  
In menus +/- scroll/change options and Select to confirm.  
textSCAN - Press and hold Select to pause scrolling text and +/- to move left and right.
5. Switches between on and standby.
6. Analogue stereo input from auxiliary device such as iPod, MiniDisc etc.
7. Light sensor for display auto-dimming function. (Do not cover)
8. Sleep timer.
9. Receives signal from remote control.
10. 3.5 mm headphone socket (mutes speakers)
11. Switches between DAB, FM, CD (& MP3) or AUX.
12. Set and select preset stations.
13. Changes the information shown on the display.
14. Press for Previous/Next track on CD/MP3  
Hold for Rewind/Fast forward on CD or Previous folder/next folder MP3.
15. Alarm snooze.
16. Open/Close CD door.
17. Stop CD or MP3 playback
18. Play/Pause CD or MP3 playback
19. Connects to the 9V DC mains adapter (supplied)
20. Alarm 1,2,3,4 set.
21. Snooze active
22. Sleep timer set.
23. Volume level. (max=10 bars)
24. AM/PM indicator
25. Clock, updated regularly by DAB signal if available.
26. DAB, FM, CD (& MP3), AUX, indicator.
27. Signal strength indicator (max=6 bars)
28. Stereo indicator.
29. CD (& MP3) play order.
30. 16 x 2 character text area.

# Getting started

1. Remove the adhesive tape securing the CD door and remove the CD mechanism transit card from inside the CD compartment.

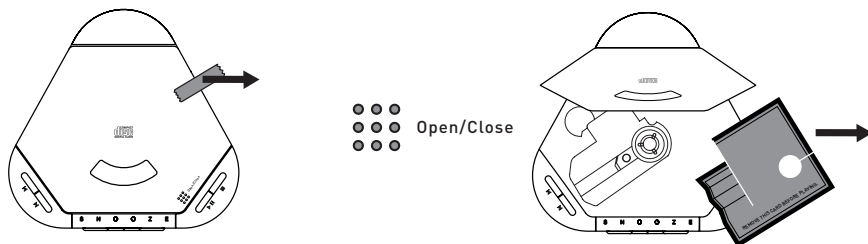

2. Insert the remote battery. Turn the remote over, push the catch up and pull out the battery drawer. Place the battery in the drawer with the **+** terminal facing up and replace the drawer.

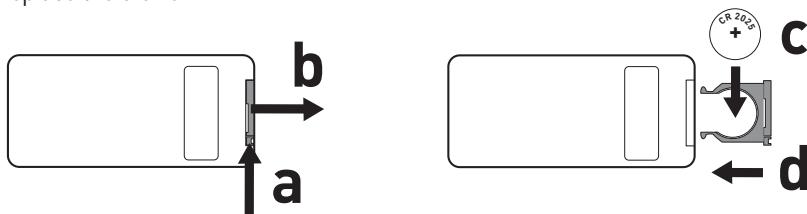

3. Hang the aerial vertically, connect the mains adapter and plug in to your power supply.

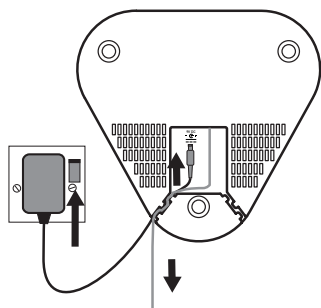

4. Press the Power button, if necessary, to switch the radio on. An autotune finds the DAB stations available in your area and selects one.

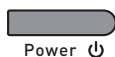

5. Use the +/- buttons to see all the available stations. Push Select to change to another station.



6. Push Source button to listen to FM, CD or AUX.



# Using your CHRONOS CD

## Switching between DAB, FM, CD (&MP3), AUX

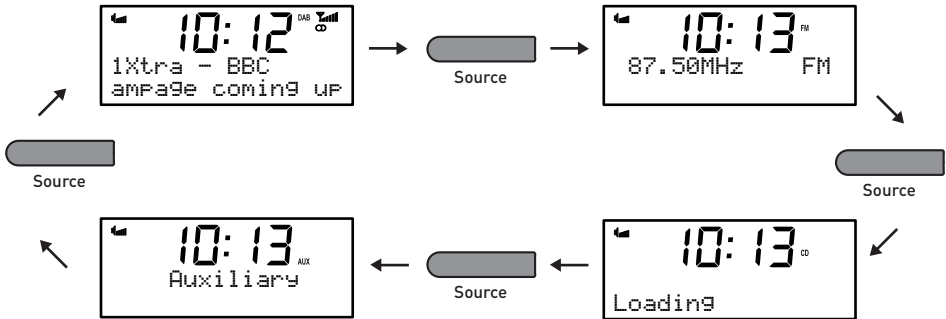

## Changing stations

### DAB



### FM

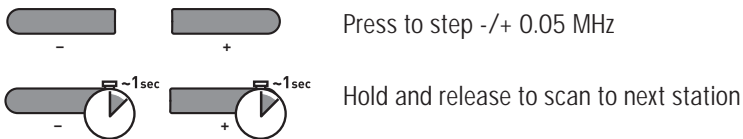

## Changing the information shown on screen

Info

1. Scrolling text broadcast by most DAB stations and FM (RDS) stations.
2. Content being broadcast e.g. Pop music.
3. DAB Multiplex in which the current station is broadcast.
4. Time and date updated regularly by the most recent DAB station.
5. Frequency for the current station.
6. DAB signal data rate and a stereo or mono indicator.
7. DAB signal quality; 85 to 100 Good, 70 to 84 OK, 0 to 69 poor.

Note The Info button only works in FM if the station has RDS data.

# textSCAN™ - pause and control scrolling text (DAB & FM)

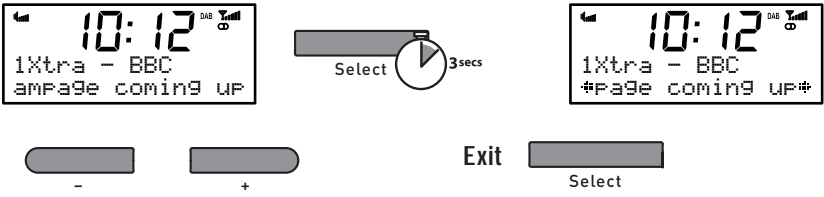

## Setting and selecting presets

Store up to 30 DAB and FM radio stations in a combined list for easy access.

### To set a preset

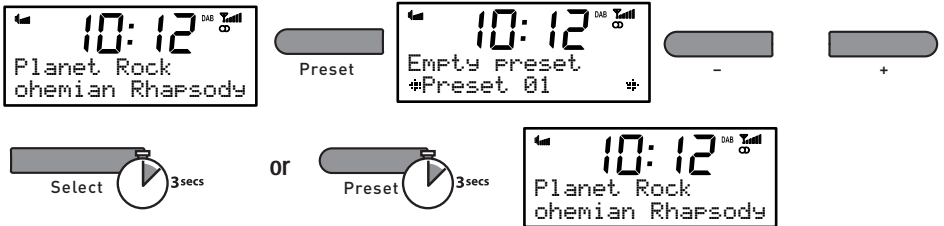

### To select a preset

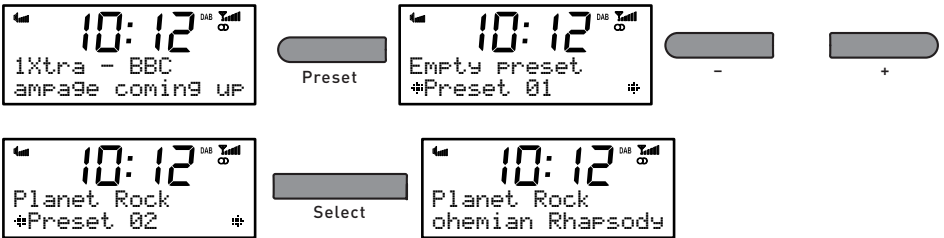

# Playing a CD

CHRONOS CD can play ordinary audio CDs, CD-R and CD-RW discs. It can also playback MP3 or WMA files from a CD.

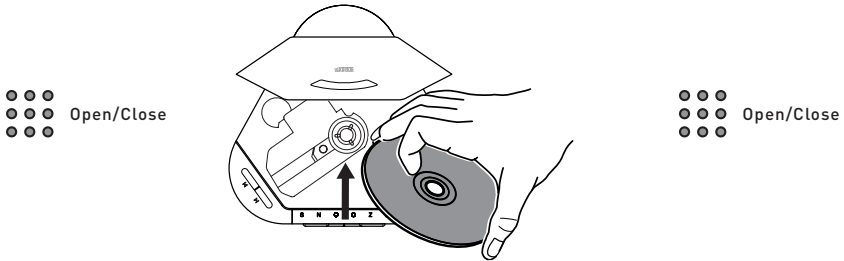

## Pause/play

Audio CD

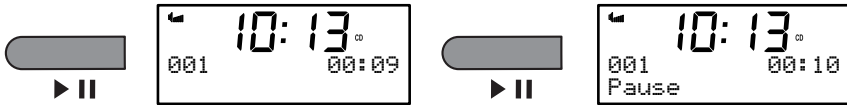

MP3/WMA CD

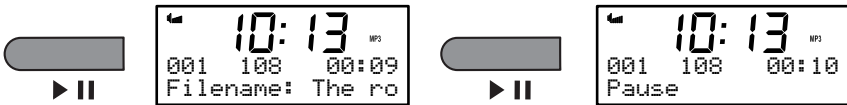

During MP3/WMA playback the screen displays track number, total number of tracks and track time on the display top line and scrolling file information (ID3/ASF text), where available, for File name, Album, Artist and Title on the bottom line (max 32 characters each).

## Stop

Audio CD



MP3/WMA CD



## Using the alarms

The alarms switch your radio on (if in standby) and tune to a station or sound a tone.

### To set/change an alarm

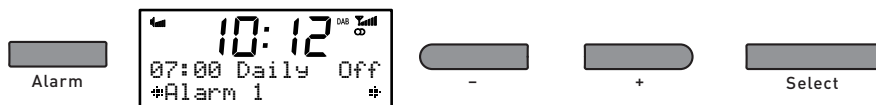

Select one of the 4 alarms. Set the alarm on or off, the time, repeat (Off=Once) and days. Choose Radio; set to Previous (last DAB or FM station) or select a Preset; CD (from first track) or Tone alarm and set the alarm volume. The alarm symbol is displayed when the alarm is set.

### To snooze an alarm



### To cancel an alarm



### Changing the alarm snooze time



You can change how long the alarm snoozes for when you touch the Snooze button. The default is 9 minutes.

## Using the sleep timer

The sleep timer switches your radio into standby after a number of minutes.

### To set/change the sleep timer

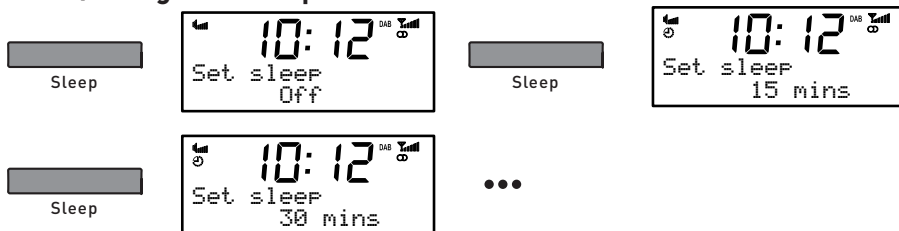

### To cancel the sleep timer

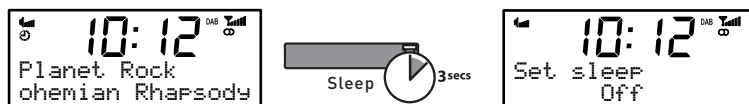



Menu

# Changing your radio setup

## DAB only options

### Station Order

Alphanumeric	Lists all stations in alphanumeric order.
Fav station	Lists the ten most listened to stations first on the station list in alphanumeric order.
Active station	Lists active stations first on the station list.
Multiplex	Lists stations in groups according to their multiplex.
Trim stations	Removes inactive stations from the station list.

### Autotune

Scans all DAB Band III frequencies for stations and adds any new ones to the station list. To stop an Autotune press Select.

### DRC value

DRC (Dynamic Range Control) value makes the quieter sounds in a DAB broadcast easier to hear at low volume or in a noisy environment. Check with the broadcasters to find out if they use DRC.

DRC full	Applies the DRC level as sent with the broadcast.
DRC half	DRC level is set to half that sent with the broadcast.
DRC off	Any DRC level broadcast will be ignored.

### Manual tune

Shows DAB signal level which can help you find the best position for your radio.

1. Use the +/- buttons to scroll through different channels and push Select to choose one (UK stations are in the range 11B to 12D). You see a signal level display. The empty block indicates the minimum required level for reception and the filled blocks indicate the current level.
2. Move your aerial/unit and to try to raise the current level to the empty block or beyond. Once you have a good signal the display will show the multiplex name and add the stations to the station list.
3. Push the Menu button to exit or +/- and Select buttons to change channel.

## FM only options

### FM stereo mode

Choose from Stereo or Mono - mono may improve audio clarity where stereo signals are weak.

## CD only options

### CD play order

Choose the order CD tracks are played in. Choose from Normal, Repeat one (repeats current track), Repeat folder (tracks in current folder (MP3/WMA) or all (normal CD)), Repeat all (whole CD) or Random.

# General options

## Display

Choose whether the screen backlight is Always on, Timed (turns on when a button is pressed) or Auto dimming (alters the display backlight automatically depending on the ambient light levels in your room) when the unit is Active (on) and in Standby.

You can also set the screen brightness and contrast.

## Clock

### *Clock set*

Manually set the time and date if required. If you have good DAB reception these will automatically be updated from the DAB radio signal.

### *12/24 Hour set*

Choose 12 hour or 24 hour clock display.

## Audio

Set the Treble and Bass levels.

# Hints and Tips

## *(<</>>) Secondary DAB services*

Secondary services accompany some stations, providing extra information or alternative content and may only be broadcast at certain times. If a station has secondary services available, the station shows '>>' next to its name in the station list and the secondary service appears next to the station in the list. A secondary service has a '<<' before its name in the station list.

## *(?) Inactive or unavailable DAB stations*

Inactive or unavailable stations are those which appear on the station list but are not currently available. Inactive stations have a '?' before their name on the station list. If you select a station which has this symbol, your radio tries to tune in or returns to the previous station.

## *Display says 'No stations available'*

Check that your aerial is fully extended. Use Autotune to search for stations. Try adjusting your aerial or radio position.

## *Resetting your radio*

Resetting your radio removes all presets, stored stations and favourite station settings and resets all options to defaults. To reset:

1. Press and hold the Menu button for three seconds.
2. Press Select to confirm the reset or press no buttons to cancel the reset.

## *The screen is very dark*

Check the Display settings. Check that the light sensor is not obstructed if Auto dimming is selected.

# Technical Specifications

<b>DAB</b>	Fully compliant with ETS 300 401 and capable of decoding all DAB transmission modes 1-4 up to and including 192 kb/sec.
<b>CD player</b>	Compatible with CD, CDRW, MP3, WMA
<b>Speakers</b>	Two 3 inch x 1.5 inch oval, 8 ohm impedance.
<b>Frequency range</b>	DAB – Band III (174-240 MHz), FM – 87.5-108 MHz
<b>Input connectors</b>	9V DC power adapter socket (230 V adapter supplied) 3.5 mm Aux in for connection of auxiliary devices.
<b>Output connectors</b>	3.5 mm socket for headphones.
<b>Remote control</b>	Infrared remote control.
<b>Aerial</b>	Wire aerial attached.
<b>Mains power supply</b>	230 V AC to 9V (1.5 A) DC external power adapter (supplied).
<b>Approvals</b>	CE marked. Compliant with the EMC and Low Voltage Directives (89/336/EEC and 73/23/EEC).
<b>Dimensions</b>	195 mm (width) x 125 mm (height) x 185 mm (depth).



## Warranty information

Imagination Technologies Ltd. warrants to the end user that this product will be free from defects in materials and workmanship in the course of normal use for a period of two years from the date of purchase. This guarantee covers breakdowns due to manufacturing or design faults; it does not apply in cases such as accidental damage, however caused, wear and tear, negligence, adjustment, modification or repair not authorised by us. Please return your warranty card or visit [www.pure.com/register](http://www.pure.com/register) to register your product with us. Should you have a problem with your unit please contact your supplier or contact PURE Support at the address shown on the rear of this manual.

## Garantie-Informationen

Imagination Technologies Ltd. garantiert dem Endbenutzer, dass dieses Produkt für die Dauer von zwei Jahren ab Kaufdatum bei normalem Gebrauch frei von Schäden an Material oder Verarbeitung ist. Diese Garantie umfasst Ausfälle aufgrund von Herstellungs- und Konstruktionsfehlern; sie gilt nicht für Unfallschäden, die auch immer verursacht, Verschleiß, Fahrlässigkeit und Veränderung oder Reparatur durch von uns nicht autorisierte Personen. Senden Sie Ihre Garantiekarte ein oder registrieren Sie Ihr Produkt bei uns unter [www.pure.com/register](http://www.pure.com/register). Sollten Sie mit Ihrem Gerät ein Problem haben, wenden Sie sich an Ihren Verkäufer oder den PURE Support. Die Adresse finden Sie auf der Rückseite dieser Bedienungsanleitung.

## Garantie

Imagination Technologies Ltd. garantit à l'utilisateur que le présent produit est exempt de défauts en termes de matériaux et de main-d'œuvre, dans le cadre d'une utilisation normale, pour une période de deux ans à compter de la date d'achat. La présente garantie couvre les pannes dues à un défaut de conception ou de fabrication; elle ne prend pas en compte les dommages accidentels, quelle que soit leur cause, l'usure normale du produit, ainsi que tous dommages dus à la négligence, à la modification, au réglage ou à la réparation effectuée(e) sur l'appareil sans notre autorisation. Veuillez renvoyer votre carte de garantie ou visiter le site [www.pure.com/register](http://www.pure.com/register) pour enregistrer votre produit auprès de nos services. En cas de problème avec votre appareil, veuillez contacter votre fournisseur ou le centre d'assistance PURE, à l'adresse indiquée au dos du présent manuel.

## Informazioni sulla garanzia

Imagination Technologies Ltd. garantisce all'utente finale che il presente prodotto è esente da difetti di materiale e fabbricazione in condizioni normali di utilizzo per un periodo di due anni a partire dalla data di acquisto. La presente garanzia copre i danni dovuti a difetti di fabbricazione o progettazione; non si applica in casi quali danni accidentali, in qualsiasi modo siano stati provocati, usura, negligenza, regolazione, modifica o riparazione non autorizzate. Restituire la scheda della garanzia oppure visitare il sito [www.pure.com/register](http://www.pure.com/register) per registrare il prodotto. In caso di problemi relativi all'unità, contattare il proprio fornitore oppure contattare il Supporto tecnico PURE all'indirizzo indicato sul retro del presente manuale.

## Garantioplysninger

Imagination Technologies Ltd. garanterer over for slutbrugerne, at dette produkt ikke er fejlbæftet, hvad angår materialer og håndværksmæssig udførelse ved normal brug i to år fra købsdatoen. Denne garanti dækker sammenbrud, der skyldes fremstillings- eller designfejl. Den dækker ikke i tilfælde, hvor enheden beskadiges som følge af hændeligt uheld, uanset hvordan dette sker, samt sliitage, uagtsomhed, justering, ændring eller reparation, som ikke er godkendt af os. Du bedes returnere garantikortet eller besøge [www.pure.com/register](http://www.pure.com/register) for at registrere produktet hos os. Hvis der skulle opstå problemer med enheden, bedes du kontakte leverandøren eller PURE Support på adressen, der er angivet på bagsiden af denne vejledning.

## Informatie over de waarborg

Imagination Technologies Ltd. waarborgt de eindgebruiker dat dit product vrij is van defecten in de materialen en werken bij normaal gebruik voor een duur van twee jaar vanaf de datum van aankoop. Deze garantie dekt defecten door productie- of ontwerpfouten; het is niet van toepassing in gevallen als accidentele schade, hoe ook veroorzaakt, slijtage, onachtzaamheid, instelling, wijziging of reparatie die door ons niet werd goedgekeurd. Gelieve uw garantiekartaar terug te sturen of bezoek [www.pure.com](http://www.pure.com) om uw product bij ons te registreren. Indien u een probleem hebt met uw apparaat, gelieve uw leverancier te contacteren of contacteer PURE Support op het adres op de achterzijde van deze handleiding.

## Disclaimer

Imagination Technologies Limited makes no representation or warranties with respect to the content of this document and specifically disclaims any implied warranties of merchantability or fitness for any particular purpose. Further, Imagination Technologies Limited reserves the right to revise this publication and to make changes in it from time to time without obligation of Imagination Technologies Limited to notify any person or organization of such revisions or changes.

## Ausschlusshinweis

Imagination Technologies Limited gewährt keine Garantien für den Inhalt dieses Dokuments und lehnt insbesondere implizierte Garantien für die allgemeine Gebrauchstauglichkeit bzw. die Eignung für spezielle Zwecke ab. Weiterhin behält sich Imagination Technologies Limited das Recht vor, diese Publikation von Zeit zu Zeit zu überarbeiten und zu ändern, ohne dass daraus eine Verpflichtung für Imagination Technologies Limited entsteht, irgendeine Person oder Organisation von solchen Änderungen in Kenntnis zu setzen.

## Avis de non-responsabilité

Imagination Technologies Limited refuse toute représentation ou garantie vis-à-vis du contenu du présent document et refuse spécifiquement toute garantie implicite de valeur marchande ou d'adéquation à un usage spécifique. En outre, Imagination Technologies Limited se réserve le droit de réviser la présente publication et d'y apporter des modifications, quand elle le souhaite, sans obligation de sa part de notifier toute personne ou organisation desdites révisions ou modifications.

## Dichiarazione di non responsabilità

Imagination Technologies Limited non si assume alcuna responsabilità rispetto al contenuto del presente documento, in particolare non riconosce nessuna garanzia implicita di commerciabilità o idoneità per uno scopo specifico. Inoltre, Imagination Technologies Limited si riserva il diritto di revisionare la presente pubblicazione e di apportarvi modifiche periodiche senza alcun obbligo di notifica a qualsiasi persona o organizzazione.

## Ansvarsfraskrivelse

Imagination Technologies Limited afgiver ingen garantier eller erklæringer med hensyn til indholdet af dette dokument og fralægger sig i særdeleshed eventuelle stilltiede garantier for salgbarhed eller egnethed til et bestemt formål. Endvidere forbeholder Imagination Technologies Limited sig ret til at revidere denne publikation og foretage ændringer fra tid til anden, uden at Imagination Technologies Limited er forpligtet til at underrette nogen person eller organisation om sådanne revideringer eller ændringer.

## Vrijwaring

Imagination Technologies Limited geeft geen verklaring of garanties met betrekking tot de inhoud van dit document en wijst specifiek elke verantwoordelijkheid af met betrekking tot om het even welke onuitgesproken garanties naar verhandelbaarheid of geschiktheid voor enig bijzonder doel. Daarenboven behoudt Imagination Technologies Limited zich het recht voor om deze publicatie te reviseren en af en toe veranderingen aan te brengen zonder de verplichting voor Imagination Technologies Limited om personen of organisaties van deze revisies of veranderingen op de hoogte te brengen.

# www.pure.com

PURE Digital  
Imagination Technologies Ltd.  
Home Park Estate  
Kings Langley  
Herts, WD4 8DH  
UK

 +44 (0)1923 277477 support  
+44 (0)1923 277488 sales  
 +44 (0)1923 270188  
 support@pure.com  
sales@pure.com

PURE Digital  
Karl-Marx Strasse 6  
64589 Stockstadt/Rhein  
GERMANY

 +49 (0)6158 878872 sales  
 +49 (0)6158 878874  
 sales\_gmbh@pure.com

PURE Digital - Vertrieb über:  
TELANOR AG  
Unterhaltungselektronik  
Bachstrasse 42  
4654 Losterf  
SCHWEIZ/SWITZERLAND

 +41 (0)62 285 95 95 sales  
 +41 (0)62 285 95 85  
 info@telanor.ch  
www.telanor.ch

*Powered by*  
  
Imagination  
TECHNOLOGIES

  
Digital Audio Broadcasting

digital  radio



((FM))  R-D-S

