

MFJ-1798 Vertical Antenna

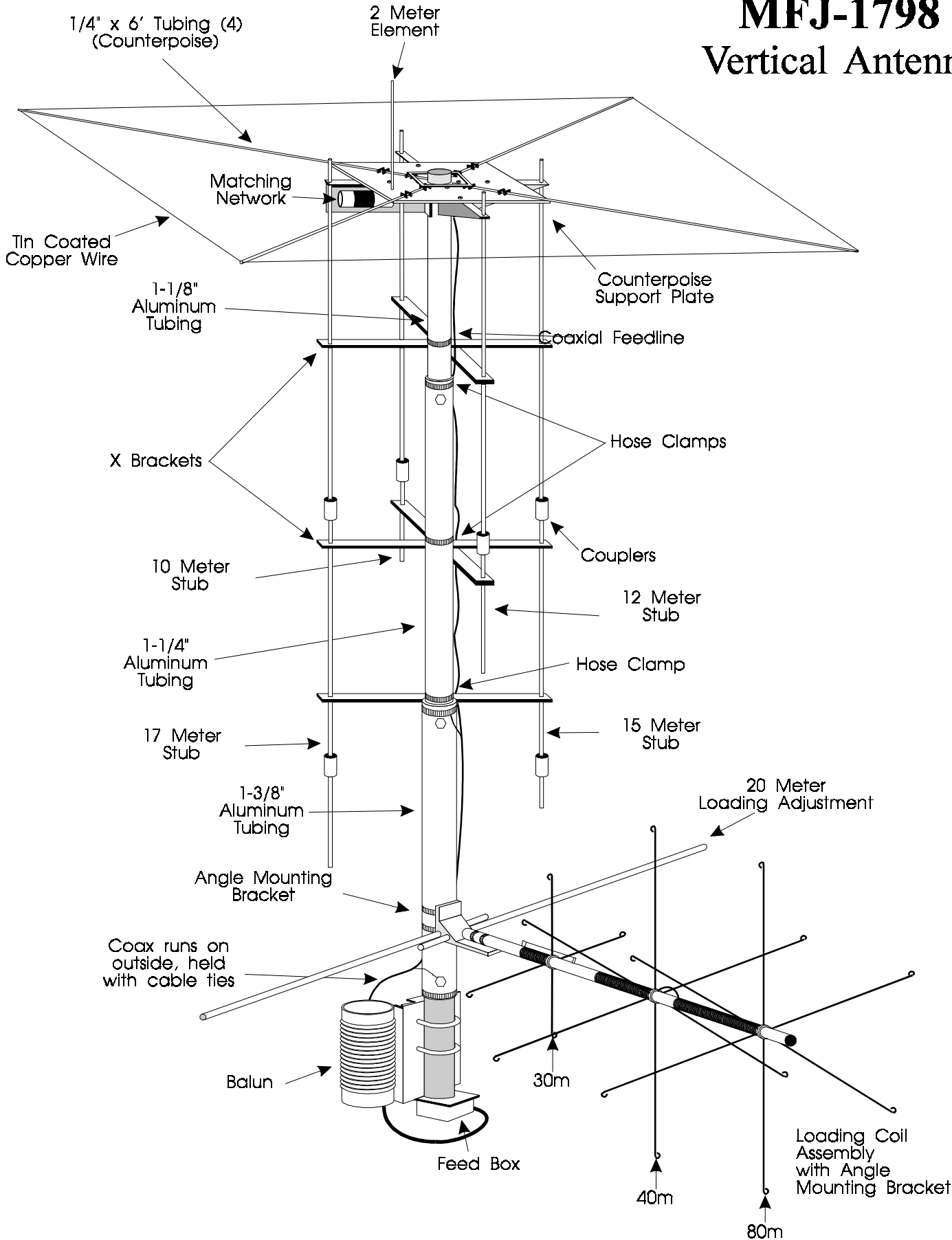

NOTE: This Drawing Is Not To Scale!

MFJ-1798 Vertical Antenna

INTRODUCTION and THEORY OF DESIGN

The MFJ-1798 is an 80 through 2 meter ground independent vertical antenna. This antenna has several unique features including an inverted radiating element, a fully elevated counterpoise, lumped constant end loading, and linear stub *decoupling*. These unique features eliminate the traditional problems encountered in ground independent multi-band vertical designs.

Established antenna theory dictates that maximum radiation occurs in the high current portion of the antenna. While conventional antennas generally place the highest current at the bottom or center of the radiating element, the MFJ-1798's unique design places the highest current and the maximum radiation point at the very *top* of the radiating element. This feature produces the lowest wave angle possible for a given antenna height, and elevates the radiating section away from the lossy earth.

It is a well-documented fact that bending or folding a radiating element at a high current point reduces antenna system efficiency. The MFJ-1798 eliminates all bending or folding of the important high current areas by using *linear decoupling* stubs on frequencies above 14 MHz. These linear decoupling stubs provide low loss operation without compromising bandwidth. Efficient lumped constant end loading produces the highest efficiency possible on frequencies below 14 MHz.

Counterpoises must be an appreciable fraction of a wavelength above ground if losses are to be minimized. The MFJ-1798 design places the counterpoise at the *top* of the radiating element. This provides maximum separation between the counterpoise and the lossy earth. For example, a ground mounted MFJ-1798 has a counterpoise elevation of one half wavelength on 10 meters.

DESCRIPTION

The MFJ-1798 is a multi-band vertical that operates on every amateur band between 80 and two meters. The inverted radiating element is constructed from heavy duty 6061-T6 aluminum tubing. This antenna performs as a full size inverted ground plane on all bands above 14 MHz, and as an efficient end loaded vertical on 30, 40, and 80 meters.

The 12 feet diameter counterpoise is constructed by mounting four six feet long tubes on a fiberglass insulated plate at the top of the antenna. The tubing has a wire that circles the perimeter of the counterpoise to stabilize the support and increase the capacitance of the hat.

A 1/4 wave two meter vertical is mounted above the counterpoise.

Four linear decoupling stubs are tuned for 10, 12, 15, and 17 meters. These stubs are constructed from 3/16" solid aluminum rod and supported by fiberglass insulators.

A small adjustable "T" section near the bottom allows adjustment of the resonant frequency of the full size radiating element on 20 meters.

A three section loading coil with capacitance hats for 30, 40, and 80 meters is mounted next to the 20 meter "T" adjustment near the lower end of the antenna.

The base section contains the air core high power choke balun. This balun uses Teflon insulated coaxial cable. The base section normally mounts on masts below 1-1/2" diameter, but additional holes are provided to accept masts up to 2" diameter with user supplied clamps.

The power rating of this antenna varies from band to band. The PEP ratings are primarily determined by the voltage breakdown of the components, while the CW ratings are generally determined by component heating.

The following chart lists the power rating and the 2:1 VSWR bandwidth of this antenna:

Band	Power			Bandwidth
	CW	SSB	RTTY	
80	1000	1500	750	35KHz
40	1250	1500	1000	25KHz
30	1500	1500	1500	370KHz
20	1500	2500	1500	700KHz
17	1500	2500	1500	680KHz
15	1500	2500	1500	800KHz
12	1500	2500	1250	750KHz
10	1500	2500	1250	2.0MHz
6	300	750	300	2.4MHz
2	200	200	200	7MHz

CHOOSING A LOCATION FOR THE ANTENNA

WARNING: Improper installation and assembly can be hazardous! Read these instructions thoroughly before attempting to assemble, install or operate this product! High power transmitting devices produce voltages that can cause severe burns or other injuries.

For the best performance on receiving and transmitting, mount this antenna in a clear location at least a few feet above or 70 feet away from buildings, towers, feedlines, utility wires, and other antennas. While your own ingenuity and particular circumstances will determine the final mounting method, we will pass along few rules that can not be neglected.

Never mount this antenna in a location that will permit unsuspecting people to come in contact with the loading spokes or any other part of the antenna.

Never mount this antenna where a mechanical failure might allow the antenna to contact power lines or other utility wires.

Always ground the feed line at the point where it enters a building to a good earth ground for lightning protection.

MOUNTING LOCATION

WARNING: Always mount this antenna so that it is out of the reach of adults as well as children. Contact with any part of this antenna can cause injury and / or severe RF burns.

The ideal antenna mounting location is an open area either above or more than 70 feet away from other large conducting objects or antennas. If such a location is **not** available, the *least obstructed* location should be selected.

This antenna should be mounted on a rigid support. The mounting clamps supplied with this antenna accept masts between one and 1.5 inches outside diameter. Additional holes in the mount of this antenna will accept mast clamps up to 2" OD. Soft or thin wall masts should not be used to mount this antenna to any supporting structure.

The MFJ-1798 will perform quite well in ground mounted installations. The lower end of the antenna should be at least 5 ft above ground level. If the antenna is ground mounted, it **MUST** be surrounded with a protective non-metallic fencing. This will increase the safety and lessen the likelihood of damage to the antenna.

GROUNDING

Unlike most verticals, this antenna does not require an RF ground system. However, some sort of earth connection is a good idea to avoid lightning damage to the station equipment and to improve operator safety.

The feedline's shield should be grounded at the entrance point of the building *before* it reaches the operating position. Failure to do so can result in lightning damage to the equipment. This will also help prevent voltage from being applied to the antenna support if the station equipment ever develops a problem.

Additional lightning protection can be achieved by burying the feedline directly in the soil for a minimum of 10 feet before the cable enters the building. It is also an excellent idea to ground the mast or supporting structure.

Grounds should consist of multiple rods driven into the soil. Several long straight buried wires will assist in dissipating lightning strikes. Leads from the ground system to the antenna mast or coaxial cable should be as short and direct as possible. Sharp bends in the ground leads should be avoided. It is an excellent idea to connect all the grounds together outside the building with

smooth, wide, heavy conductors. This includes connecting the power line grounding rod to the feedlines ground.

Never use woven flexible braiding for ground connections unless *absolutely necessary*. Braiding has very high resistance to both RF and lightning. Copper flashing, wide copper foil, or large gauge solid copper wires are the proper materials for use in RF and lightning grounding applications.

The use of an in-line coaxial lightning arrestor will only offer a minimal improvement in lightning protection. The best method of protecting the station equipment is to disconnect the feedline outside the building or, at the minimum, use a safety switch to disconnect and ground the feedline.

MAINTENANCE

Your antenna is constructed of heavy duty non corrosive materials and should withstand normal climates for many years. The use of some type of coaxial connector moisture protection is recommended at the bottom coax connection and also around the matching network feed point, especially in coastal areas where salty mist is commonplace.

GE makes a pure silicone grease called "SILICONE DIELECTRIC COMPOUND" that can be applied SPARINGLY to the threaded area of the female connector. This compound, or even a clear silicone heat sink compound, will prevent moisture from entering the connector through the threads and protect the connectors from corrosion. THIS IS THE SAME TYPE OF SEALER THAT COMMERCIAL ANTENNA INSTALLERS AND CATV COMPANIES USE WITH GREAT SUCCESS.

A less desirable but adequate sealer is the automobile seam sealer commonly sold as "coax seal". This is a pliable black sealing compound.

When installing any coax sealer, NEVER completely cover the barrel of the coax connector. The sealer should ONLY be placed near the junction of the threaded part of the chassis connector and the knurled area of the male connector. This will leave the bottom of the male connector's outer sleeve open and permit the connector to "breathe" so it does NOT collect moisture!

IMPORTANT FOR COASTAL AREA OPERATORS: It is advisable to use some type of silicon spray (circuit board type from Radio Shack) on the capacitor rings to prevent corrosion between the aluminum and the stainless steel screws. Corrosion on the capacitor rings tend to make it difficult to remove the spokes to retune the antenna.

TOOLS AND TIME REQUIRED FOR ASSEMBLY

The estimated assembly time for this antenna is four to six hours. An additional one to two hours is required to adjust the antenna on all the bands. The most convenient place to adjust this antenna is on a ground mounted temporary mast or support.

The required tools are:

1/4" standard screwdriver
 3/8" open end wrench
 5/16" nut driver
 7/16" nut driver
 7/16" open end wrench
 Large wire cutters
 #1 Philips screwdriver
 #2 Philips screwdriver
 Eye protection
 Temporary mast (5-8').
 Step ladder or saw horses.
 One soldering iron

MFJ-1798 PARTS LIST

NOTE All screws and nuts are stainless steel.

As you unpack this antenna you should find the following parts. In the event any parts are missing, please contact us immediately.

Group A

Packed loose in box or inserted inside each other:

- One 30" long, 1" dia. fiberglass loading coil assembly
- One bundle of 14 long capacitance hat spokes
- One bundle of 4 short capacitance hat spokes
- One 6' long 6060-T6 aluminum tubing 1-3/8" OD.
- One 6' long 6061-T6 aluminum tubing 1-1/4" OD.
- One 50" long 6061-T6 aluminum tubing 1-1/8" OD.
- Four 6' long 6061-T6 aluminum tubing 1/4" OD.

The following bundle of 3/16" diameter aluminum rods:

Threaded rods

- Four 55"
- One 19"

Non-threaded rods

- Four 72"
- One 66.5"
- One 48"
- One 41"
- One 15"

- One fiberglass base insulator mounted on a heavy aluminum bracket

- [] One balun and feedline assembly with small coil and capacitor network

Group B (Hardware Bag #1)

- [] One bag of hardware containing the following parts groups:

- | | |
|---|---|
| <p>(1) Five #4 self tapping screws
Five 4-40 x 3/8" screws
Five 1/4-20 x 1-3/4" bolts
Four #4 flatwashers</p> | <p>(4) Twenty-nine 6-32 nuts
Two 10-32 split ring washers
Five 1/4" split ring washers</p> |
| <p>(2) Thirty 6-32 x 1/4" screws
Twelve 10-32 nuts</p> | <p>(5) Six 3/16" ID aluminum couplers
Six black cable ties
Two white nylon insulators
One red plastic cap</p> |
| <p>(3) Twenty-seven 6-32 x 5/8" screws
Two 10-32 x 1-3/4" screws
Five 1/4-20 nuts</p> | |

Group C (Hardware Bag #2)

- [] One bag of large hardware containing the following parts groups:

- | | |
|--|--|
| <p>(1) Three small aluminum "L" brackets
Three triangular aluminum brackets
One rectangular aluminum bracket</p> | <p>(3) Four counterpoise clamps with no flange
Four counterpoise clamps drilled flange
One 20 meter adjustment "U" clamp</p> |
| <p>(2) Five flat rectangular fiberglass stub insulators
One set of fiberglass and aluminum counterpoise support assembly plates
One hollow center, square aluminum plate</p> | |

Group D (Hardware Bag #4)

- [] One bag containing the following:

Seven hose clamps (4 clamps are pre-installed on the angle bracket in this bag.

3 clamps are packed loose in the bag to be used in step 9, 10,

and 11 on page 11.)

Two "U" bolts with saddle brackets, nuts, and split washers to fit masts under 1-1/2" OD

35" (approximately) of small tinned wire

One large angle bracket (with four host clamps) with slots for mounting loading coil

ADDITIONAL USER SUPPLIED MATERIALS

Please be sure you have the following additional items available:

- [] A 6'-8' rigid mast or other mounting pipe between 1" and 1.5" outside diameter (suitable materials include a heavy duty TV mast section or galvanized steel pipe).
- [] Quality low-loss 50-Ohm coax with PL-259 connectors to reach from antenna to transmitter.
- [] A SWR meter or Analyzer (MFJ-207, MFJ-249 or equivalent).
- [] Enough 1/8 to 3/16" nylon rope to reach the ground from the antenna's final location.

SAFETY PRECAUTIONS!!

Please remember the following important points:

- 1.) THIS ANTENNA IS AN ELECTRICAL CONDUCTOR.
- 2.) ANY CONTACT BETWEEN THE ANTENNA, FEEDLINE, OR SUPPORTING STRUCTURE AND POWER LINES WILL RESULT IN DEATH OR SERIOUS INJURY.

For safety please:

- 1.) DO NOT INSTALL THIS ANTENNA WHERE THERE IS ANY POSSIBILITY OF CONTACT WITH UTILITY LINES.
- 2.) DO NOT LOCATE THE ANTENNA SUPPORT WHERE IT CAN CONTACT POWER LINES IN THE EVENT OF MECHANICAL FAILURE OR ACCIDENT.
- 3.) FOLLOW THE GUIDELINES FOR ANTENNA INSTALLATIONS AS RECOMMENDED BY THE US CONSUMER PRODUCT SAFETY COMMISSION.

ASSEMBLY PROCEDURE

During assembly, refer to the drawings throughout this manual and the overview drawing on Page 1. Follow these instructions *in the exact sequence listed* to avoid errors and achieve maximum performance from this antenna.

After the antenna is assembled, you must double check the hardware for proper tightening and assembly. The resonant frequency and SWR can be tested with the antenna only a few feet above ground on a temporary support before raising it to the final tower or rooftop position.

NOTE: Wear safety glasses whenever working near or on this antenna.

WARNING! You can be killed if the antenna, feed line, or the equipment used to install the antenna accidentally contacts any utility lines. Never install an antenna near power lines!

1. Be especially careful while moving or installing this antenna. This antenna is bulky enough to cause a loss of balance if handled by an inexperienced person, or if the counterpoise or a capacitance spoke accidentally becomes snagged on a gutter, a tree limb, or any other object.
2. Mount the antenna high enough to place it completely out of reach, or protect it with a fence. The ends of the capacitance spokes and other areas of the antenna can cause eye injury, serious RF burns, or both.
3. Be sure the mast is sturdy enough to support 20 pounds of weight and a wind load of approximately 3 square feet.

Step By Step Assembly Procedure

1- Prepare a temporary 5'-6' ground-level mounting mast. This temporary mast will simplify the initial testing and adjustment of this antenna. It is also a good idea to have one or two stable supports (table, saw horses, etc.) and a 6' step ladder available at the assembly location.

2- Be sure the parts are separated in the groups listed earlier. Be sure *all of the parts* are available BEFORE beginning the actual antenna assembly.

3- Gather the following tools for the basic assembly. At minimum, these consist of:

- - #1 Philips screwdriver for capacitance spokes screws
- - #2 Philips screwdriver for other 6-32 and 10-32 screws
- - 1/4" standard screwdriver or 5/16" nut driver for hose clamp
- - 3/8 open end wrench for stub adjustments
- - Two 7/16 open end wrenches or one wrench and a 7/16" nut driver for U bolts and coupling bolts
- - Wire cutter for trimming capacitance spokes and counterpoise wire
- - Safety glasses
- - One soldering iron

NOTE - A small adjustable crescent wrench can substitute for the 3/8" and 7/16" open end wrenches.

IMPORTANT: Do not use a high torque electric screwdriver to mount the capacitance spokes or any of the #4 through #10 hardware. The hardware may be damaged if excessive or uncontrolled torque is applied during assembly.

Locate the following parts. The abbreviation "Gp" precedes the Group the part is located in:

One fiberglass base insulator and mounting bracket assembly (Gp A)
One balun and feedline assembly (Gp A)
Two 1/4-20 x 1-3/4" bolts (Gp B1)
Four 6-32 x 5/8" screws (Gp B3)
Two 1/4-20 nuts (Gp B3)
Two 1/4" split ring washers (Gp B4)
Four 6-32 nuts (Gp B4)
Two white nylon insulators (Gp B5)
U-bolt

Referring to figure 1:

- 4- Install the U-bolts on the open face of the base insulator mounting bracket. Mount the saddle clamps with the flat side against the plate, and the toothed side facing the rounded U-bolt area. These clamps will secure the antenna to the mast.
- 5- Put the lock washers over the 1/4-20 bolts and slide one of the bolts through the upper balun mounting hole on the side bracket of the base mounting plate. The upper mounting hole is located at the end of the bracket where the fiberglass insulator sticks out.
- 6- Use a white nylon insulator to space the balun away from the bracket, and be sure the balun hole closest to the end of the balun with the very long lead is bolted to the top bracket hole. Install the nut inside the balun form. Finger tighten only.
- 7- Attach the bottom balun hole to the bottom hole in the mounting assembly as explained in step 5. Snug both bolts until the split ring washer just collapses with a 7/16" wrench.
- 8- Bolt the coax connector housing to the base mounting assembly with four 6-32 x 5/8" screws and 6-32 nuts.

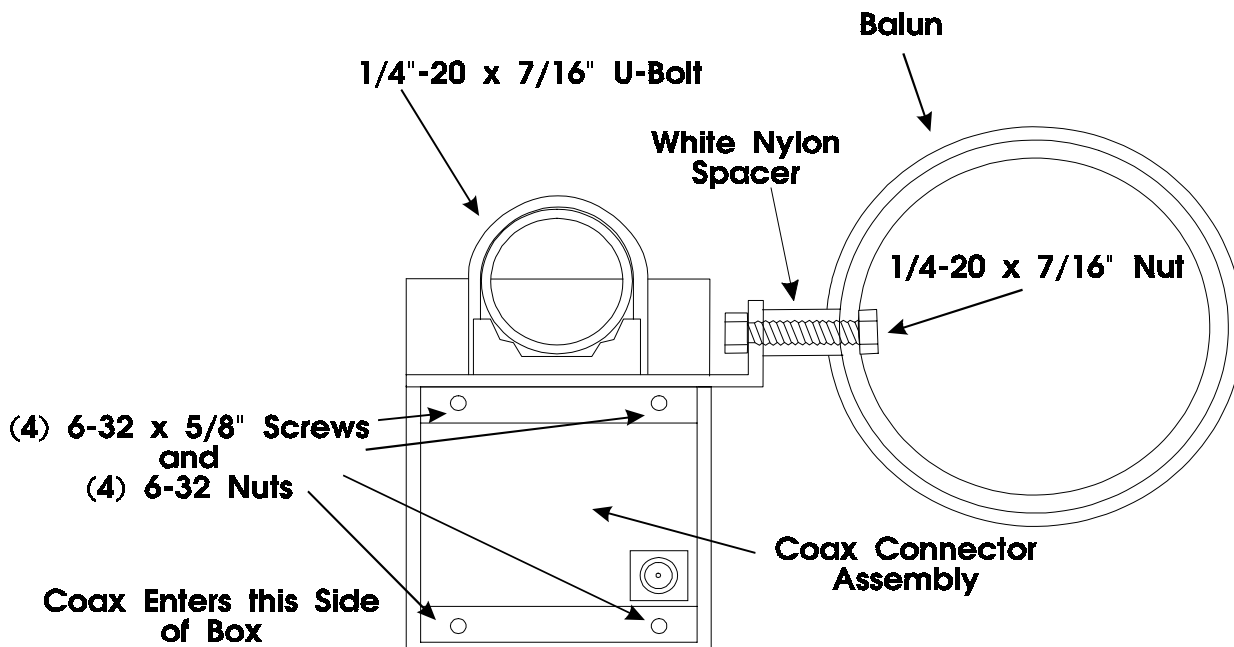

In the following steps you will refer to figure 2.

Locate the following parts:

- One 72" long 1-3/8" tubing (A)
- One 72" long 1-1/4" tubing (A)
- One 50" long 1-1/8" tubing (A)
- Three 1/4-20 bolts (B1)
- Three 1/4-20 nuts (B3)
- Three 1/4" split washers (B4)
- Three hose clamps (D)

Figure 2

You will use a 1/4" bolt with a lock washer under the 1/4" nut to secure the tubing sections together. These bolts are only used to "pin" the tubing in place. **DO NOT OVER TIGHTEN THE NUTS, doing so will flatten the tubing and actually weaken the structure.** A hose clamp provides additional support. *Be sure to properly snug the hardware after each step. The antenna can be laid on the ground during this stage of assembly.*

washer under the 1/4" nut to secure bolts are only used to "pin" the tubing

in place. **DO NOT OVER TIGHTEN THE NUTS, doing so will flatten the tubing and actually weaken the structure.** A hose clamp provides additional support. *Be sure to properly snug the hardware after each step. The antenna can be laid on the ground during this stage of assembly.*

9- Find the end of the 1-3/8" tubing that has a 1/4" hole located around four inches from the end. Insert the solid fiberglass base insulator on the base mount into this end of the tubing. Use a 1/4" bolt to secure the tubing. Place a hose clamp over the outer end of the slit area of the tubing.

10- Find the end of the 1-1/4" diameter tubing that has a 1/4" hole one inch from the end. Slide this end into the 1-3/8" tubing used in step 9. Secure the tubing with a bolt and a hose clamp over the outer end of the slit.

11- Find the end of the 1-1/8" diameter tubing with a hole at 1" from end. Slide this end into the tubing used in step 10. Secure it with a bolt and a hose clamp over the end of the slit.

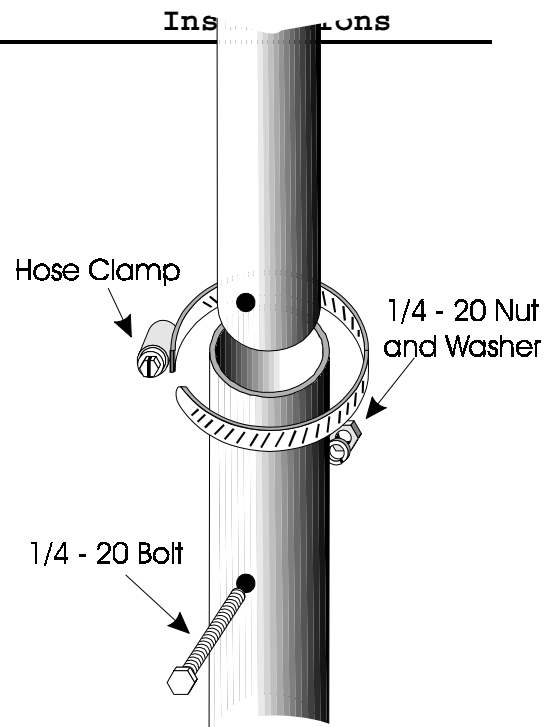

In the following steps you will refer to figure 3. Locate the following parts:

- Two 10-32 x 3/8" nuts (B2)
- Two 10-32 x 1-3/4" screws (B3)
- Eight 6-32 x 5/8" screws (B3)
- Two #10 split washers (B4)
- Eight 6-32 x 3/8" nuts (B4)
- One red plastic cap (B5)
- One rectangular support bracket (C1)
- Three triangular support brackets (C1)
- One set of fiberglass and aluminum counterpoise support assembly plates (C2)

12- Position the counterpoise mounting plate so that the edge lip (aluminum side) is facing up. Assemble the counterpoise mounting plate by using eight 6-32 x 5/8" screws to secure the three triangular and one rectangular support brackets as shown in the drawing. All the edge flanges should point clockwise. Be certain that the rectangular plate's edge flanges are facing (and next to) the 2 meter element's mounting hole. **Note:** *Do not tighten these screws at this time.*

13- Position the plate so that the brackets are facing the base of the antenna. Slide the plate over the 1-1/8" tubing (top of antenna). Align the holes and secure the plate with two 10-32 x 1-3/4" screws with split washers under the nuts. Tighten the eight 6-32 support bracket screws installed in step 12 and place the plastic cap plug over the top of the tubing.

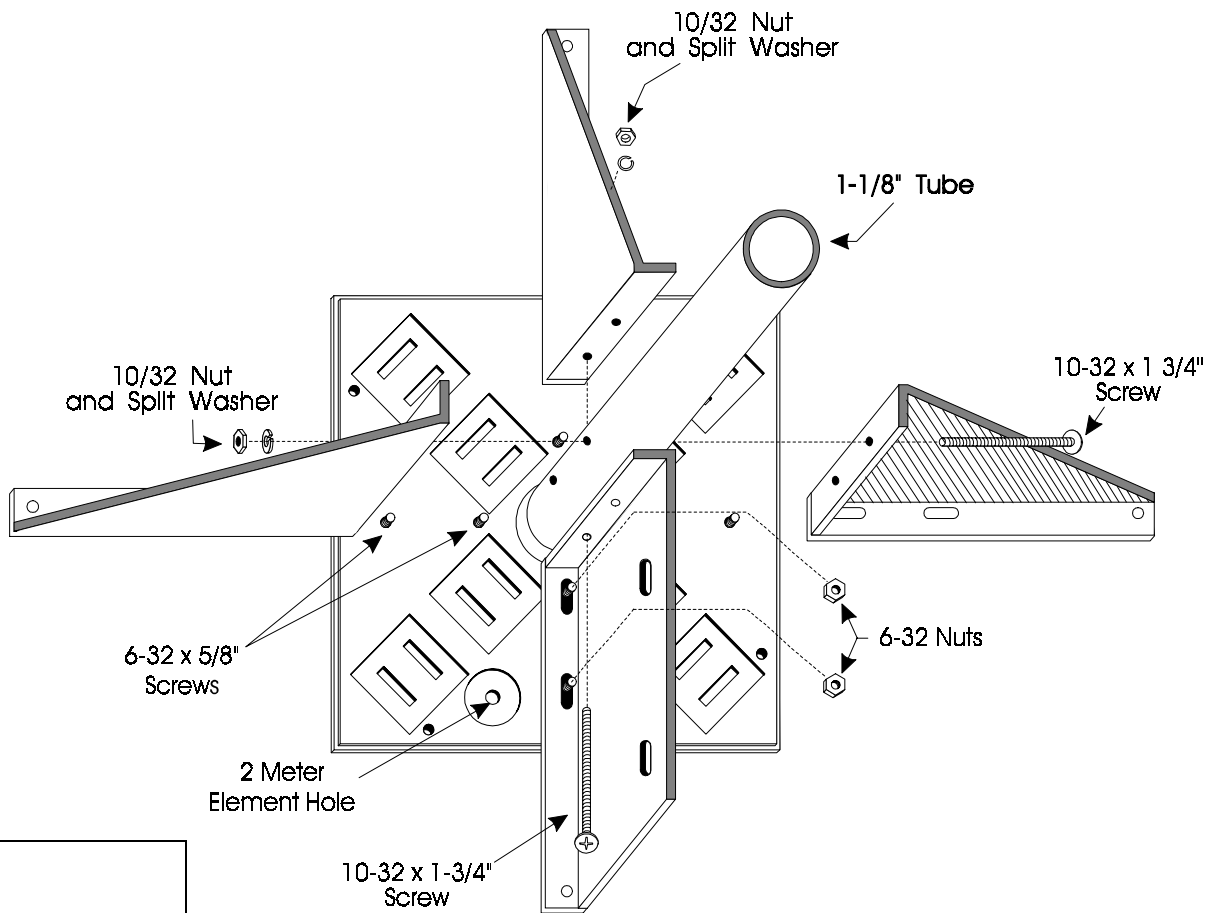

**Figure
3**

Refer to figure 4 for the next assembly steps. **Locate the following parts:**

- Six 6-32 x 5/8" screws (B3)
- Six 6-32 nuts (B4)
- Three small "L" brackets (C1)
- Five flat rectangular fiberglass stub insulators (C2)

14- With four fiberglass stub insulators and two aluminum "L" support brackets, make two insulating "X" brackets. Each "X" bracket is made by sandwiching one "L" support bracket between a pair of rectangular fiberglass insulators with two 6-32 x 5/8" screws and nuts (remember to look at figure 4).

15- Construct a fiberglass "I" bracket by assembling the remaining "L" support bracket and fiberglass insulator with two 6-32 x 5/8" screws and nuts.

NOTE: Make sure all brackets are assembled the in the same manner (fit on top of each other the same way). This is to help you to mount them on the same side of the antenna and keep them lined up.

**Figure
4**

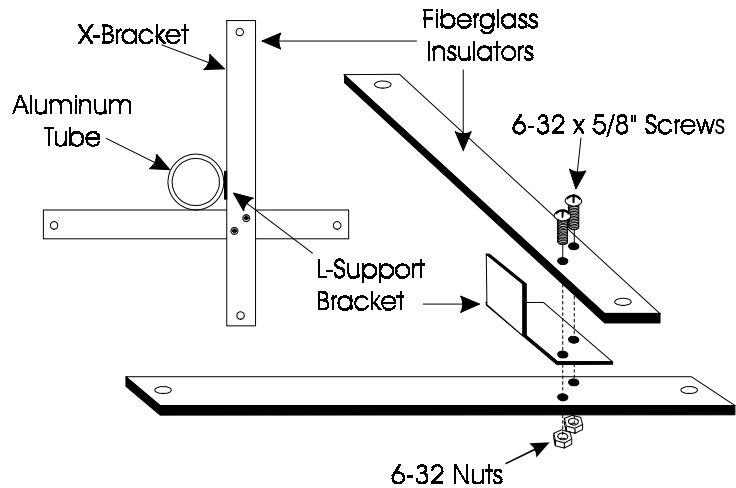

NOTE: At this point it will be useful to "prop up" the element with a small support.

16- Place a hose clamp over the 1-1/8" tubing near the junction of the 1-1/4" tubing. Install the "X" bracket under this clamp. Align the holes in the "X" bracket with the holes in the counterpoise support plate. Secure the bracket with the hose clamp.

17- Using a similar procedure, install the second "X" bracket approximately four feet closer to the base mount than the position of the first bracket.

18- Install the remaining fiberglass "I" bracket and hose clamp approximately eight feet lower than the first "X" bracket. Position it parallel with any two adjacent holes in the square support section of the feed plate and the "X" brackets. After aligning it can be secured with the clamp.

Locate the following parts:

Six 3/16" ID couplers (B5)
 Four 55" threaded rods (A)
 Two 72" non-threaded rods (A)
 One 66.5" non-threaded rod (A)
 One 48" non-threaded rod (A)
 One 41" non-threaded rod (A)
 One 15" non-threaded rod (A)
 Twelve 6-32 x 1/4" screws (B12)
 Eight 10-32 nuts

19- Install all twelve 6-32 screws finger tight in the couplers.

20- Slide four couplers half-way over the non-threaded end of the four 55" **threaded** rods. Slide two couplers half-way over the ends of the two 72" rods. Secure the couplers.

21- Pass the threaded end of the rods through the holes of the first X-bracket. Thread one 10-32 nut down 2" on the threaded portion of each rod.

22- Pass the threaded rod ends through the four stub mounting holes at the outside middle of the counterpoise support plate. Thread four 10-32 nuts on the rods and tighten snugly.

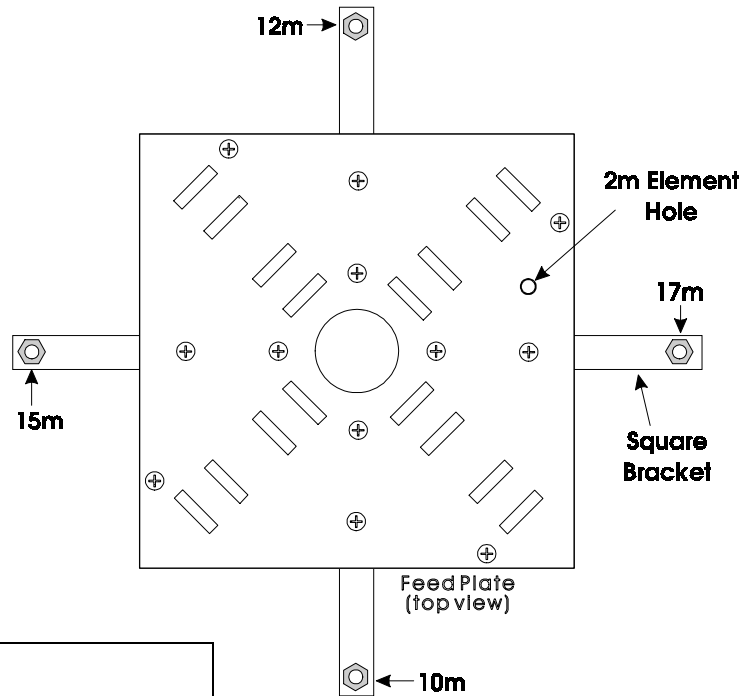

At this point you should have four 53" stubs hanging down from the counterpoise support plate. These stubs should be parallel with the main antenna mast. In the following steps, you will add the proper additional physical length to make each stub look like a 1/4 wave radiator on 10, 12, 15 and 17 meters. The 17 meter stub (the longest stub) should be located on the same side of the main mast as the balun coil. The 15 meter stub should be on the exact opposite side of the mast.

Figure 5

Note: Install the 17 and 15 meter stubs, and the 10 and 12 meter stubs, on opposite sides of the mast.

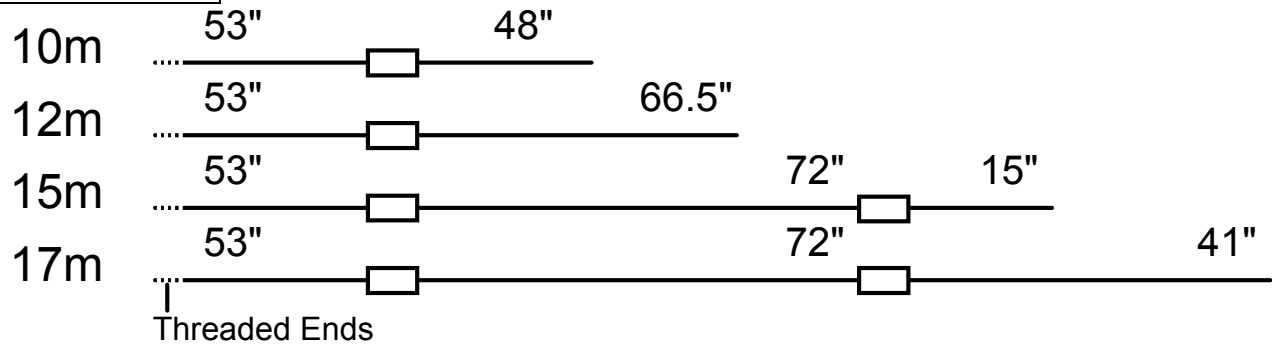

23- Connect the remaining 3/16" rods to the previously installed stub sections using the construction chart above. You will use the remaining couplers to fasten the various lengths together (refer to Figure 5 for location of elements).

Locate the following parts:

Two #10 nuts

One 19" rod threaded one end
Six black cable ties

24- Thread a #10 nut 1" in from the outer end of the 19" element. Mount the 19" element in the "2 meter element" hole of the counterpoise support plate (see page 11, figure 3). Insert the threaded end of this element into the top of the hole so it sticks out *ABOVE* the top of the antenna (away from the base mount and the other stubs). Install a second nut below the plate to secure the element. *Install this nut loosely for the moment!*

25- Dress the long coaxial cable along the main element from the balun to the top of the antenna. Ground the solder lugs near the balun end of the coaxial cable to the 1-3/8" diameter tubing by placing one lug under the hose clamp and the other lug under the 1/4" base mounting bolt. Tighten the 1/4" bolt snugly now. Ground the coax ground lugs to antenna along the feedline.

26- Secure the coaxial cable to the tubing by evenly spacing the black cable ties along the cable.

Important: Keep the Coax cable feeding at least 1-1 1/2" away from the antenna mounting bracket. Failure to do so will cause arking problems on high power between the mounting bracket and feedline, which could damage the feedline and possibly your equipment.

Locate the following parts:

Four 1/4" x 6' aluminum tubing (A)
Four 4-40 x 3/8" screws (B1)
Four 4-40 flat washers (B1)
Eight 6-32 x 5/8" screws (B3)
Ten 6-32 nuts (B4)
Four counterpoise clamps without flange (C3)
Four counterpoise clamps with flange (C3)
One square aluminum plate with hollow center (C2)
Counterpoise wire (D)
Four counterpoise clamp wires

additionally: a soldering iron and a step ladder or other 5-6' tall support

27- Thread the four 4-40 x 3/8" screws fully into the cap nut at the end of each 1/4" tubing. **Do not tighten them yet.**

28- Place the top of the antenna on a high stable support (such as a 6' step ladder) before starting the counterpoise assembly.

29- Prepare seven counterpoise clamps (four without the flange and three with the drilled flanges). Thread a 6-32 nut down the head of each 3-32 x 5/8" screw. Install three 6-32 x 5/8"

screws into the PEM™ nuts, from the outside end, of three drilled flange counterpoise clamps (Figure 6).

30- Install the four other screws by passing them through the solder lugs of the counterpoise clamp wires, then threading them into the counterpoise clamps with no flange (Figure 6).

31- Thread a 6-32 nut down to the head of a 6-32 x 5/8" screw. Pass the screw through the solder lug on the red lead that connects to the capacitor junction of the Matching Network. Thread the screw into the remaining drilled flange counterpoise clamp (see Figure 5).

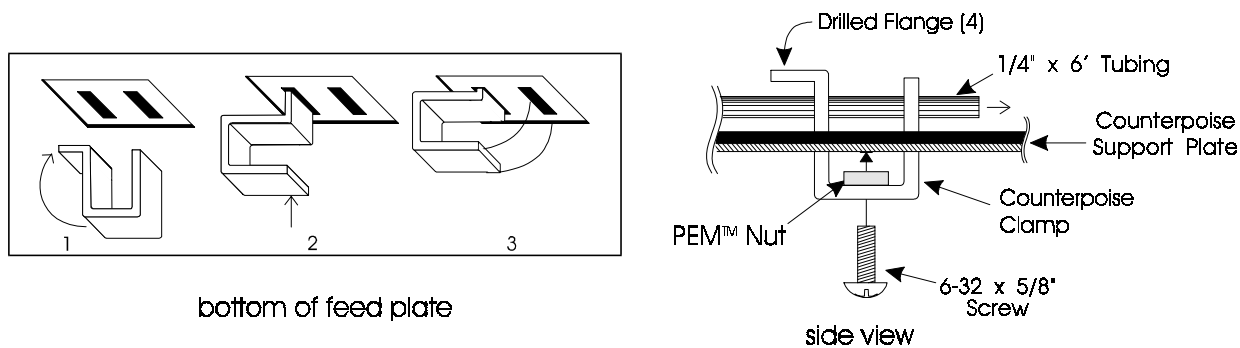

**Figure
6**

32- Install the counterpoise clamp with the red wire attached in the innermost slot located next to the square support bracket and the 2 meter element. **Make sure the drilled flange is pointing outward** (see Figures 6 and 7).

33- Install a no flange counterpoise clamp in the outside slot in the fiberglass counterpoise support plate in line with the clamp installed in the previous step.

34- Slide the empty end of the remaining 1/4" OD x 6' long aluminum element through the clamp holes. Tighten the clamp screws to secure the tubing. Use a 5/16" nut driver or small wrench to snug the nut down on the solder lug (see Figs. 6 and 7).

Note: Make sure the element end is between 1/4 and 1/2" away from the main element 1-1/8" tubing. Be sure that the solder lugs are only touching the metal they are bolted to, and NOT accidentally touching (or very close to) any other metal parts!

35- Connect the white wire (from trace that connects to the coax shield) by placing the lug over either 6-32 mounting screw on the rectangular counterpoise plate support bracket. Installing a new 6-32 nut over the solder lug to secure it (see figure 7).

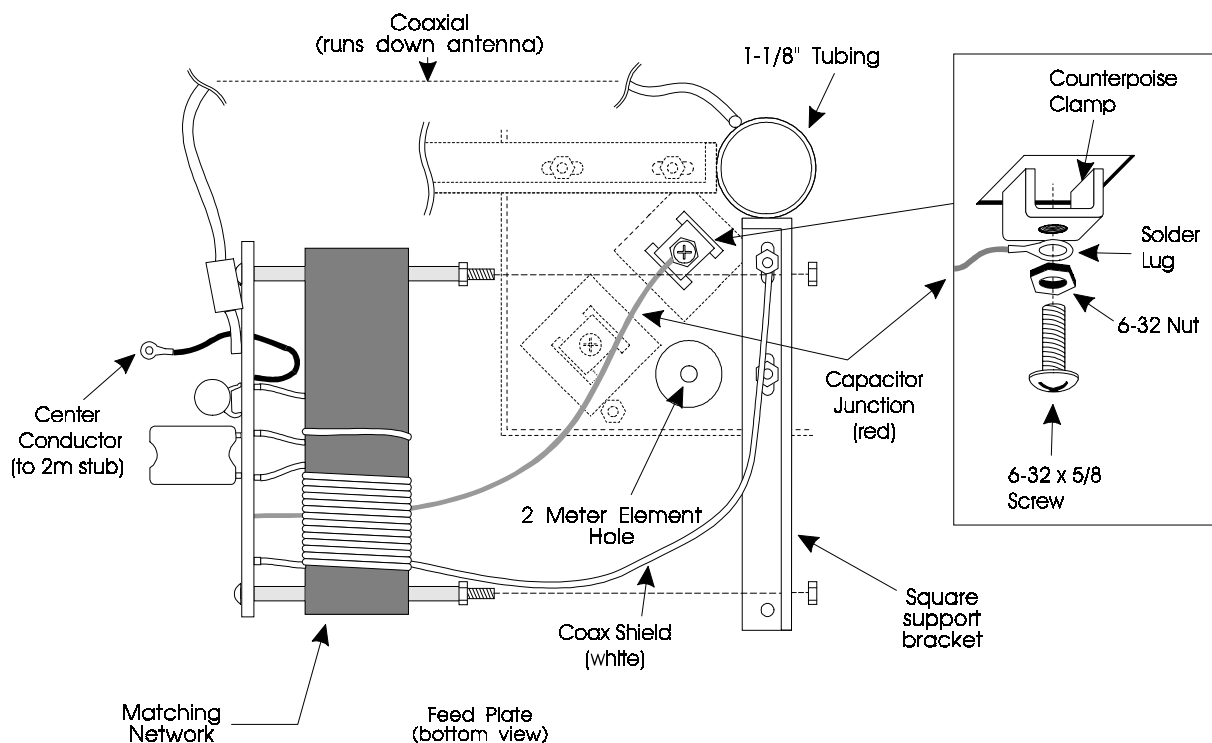

Figure 7

36- Connect the black wire (from the coax center conductor) to the 2 meter element by removing the #10 mounting nut and replacing it over the black wire's solder lug (*see Figure 5*).

37- Attach the matching network to the square support bracket (coaxial cable towards center of antenna) by inserting the 6-32 x 3" screws in the matching holes. Install two new 6-32 nuts to secure the coil's mounting screws to the rectangular bracket (*see Figure 7*).

38- Mount the three remaining 1/4" x 6' long tubes in position using the remaining clamps. Be sure that the clamps with the drilled flange are in the innermost slots and have their flanged ends pointed outwards. Be sure the tubes are between 1/4 and 1/2 inch from the 1-1/8" main element.

Tighten the no-flange counterpoise clamps ONLY.

39- The counterpoise wires connected together with the square hollow center plate. Use four #4 self-tapping screws to attach the hollow center square plate to the flange holes of the inner counterpoise clamps (see Figure 8). **DO NOT OVER TIGHTEN THE SCREWS** but be sure that they are fully seated on the plate's surface.

40- Use a 5/16" nut driver to tighten all 6/32 nuts on the flanged counterpoise clamps and the non-flanged clamps. **Make sure that counterpoise rods are mechanically secure.**

WARNING: The counterpoise tubing must stay at least 1/4" from the 1-1/8" tubing.

41- Connect the outer ends of the counterpoise provided. Connection is made by wrapping the wire screw *between the flat washer and the cap nut* on counterpoise rod *before* tightening the screw.

41- Mount the angle mounting bracket of the trap assembly at the bottom of the antenna and make sure it is pointing to the opposite side of the 17m stub and away enough from the balun (refer to Figure 10).

42- Raise the antenna to a temporary mast (5-8'), and secure it using the two U-bolts on the mounting base.

Warning: Be especially careful when moving or mounting this antenna. The weight and length of this antenna can cause a loss of balance if handled by an inexperienced person, or if the counterpoise or a capacitance spoke accidentally becomes snagged on a gutter, a tree limb, or any other object.

Locate the following parts:

Twelve long capacitance hat spokes (A)

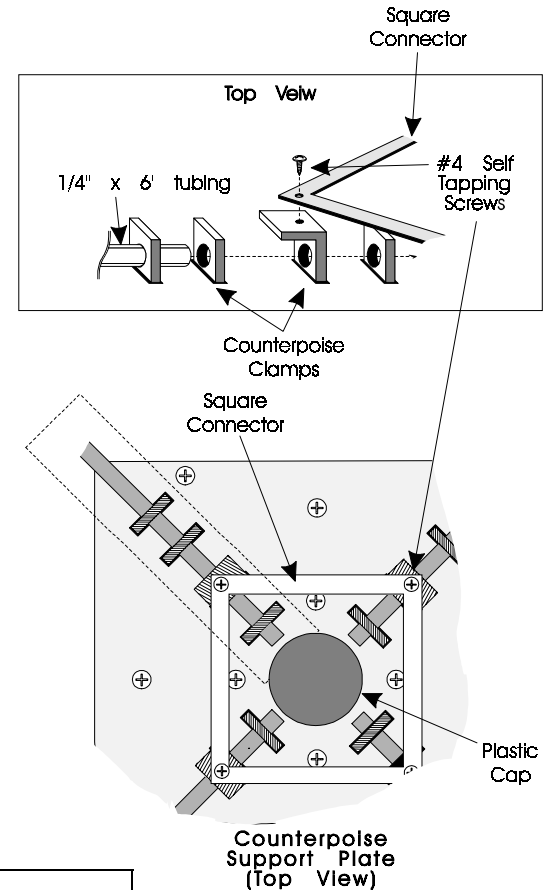

**Figure
8**

together using the wire *once* around the 4-40 the end of the

Four short capacitance hat spokes (A)
 Sixteen 6-32 x 1/4" screws (B2)
 One 30" fiberglass loading coil assembly (A)
 Four hose clamps (D)

Warning: *Only tighten the screw that fastens the loading coil terminal lugs to the capacitance hat if the ring is loose. Never excessively tighten the screw or you can **BREAK** the fiberglass form. If the terminal lugs are loose, tighten the NUT against the lug.*

43- Install the short 6-32 x 1/4" screws in the rings of loading coil assembly. **Do not thread the screws completely in.** Install six long capacitance spokes in the six holes in the 80-meter capacitance hat ring. Tighten the screws until the spokes are snug. At this point you should be able to stand the coil form on its end. Use either a #5 or #2 screwdriver here (see Figure 9).

44- Install the six remaining long spokes in the six holes in the 40 meter capacitance hat ring, then install four short spokes in the 30 meter capacitance hat ring.

45- Mount the coil assembly in the angle mounting bracket. Place the solder lug under the first hose clamp. Tighten both hose clamps. **Do not over tighten the hose clamps, you may break**

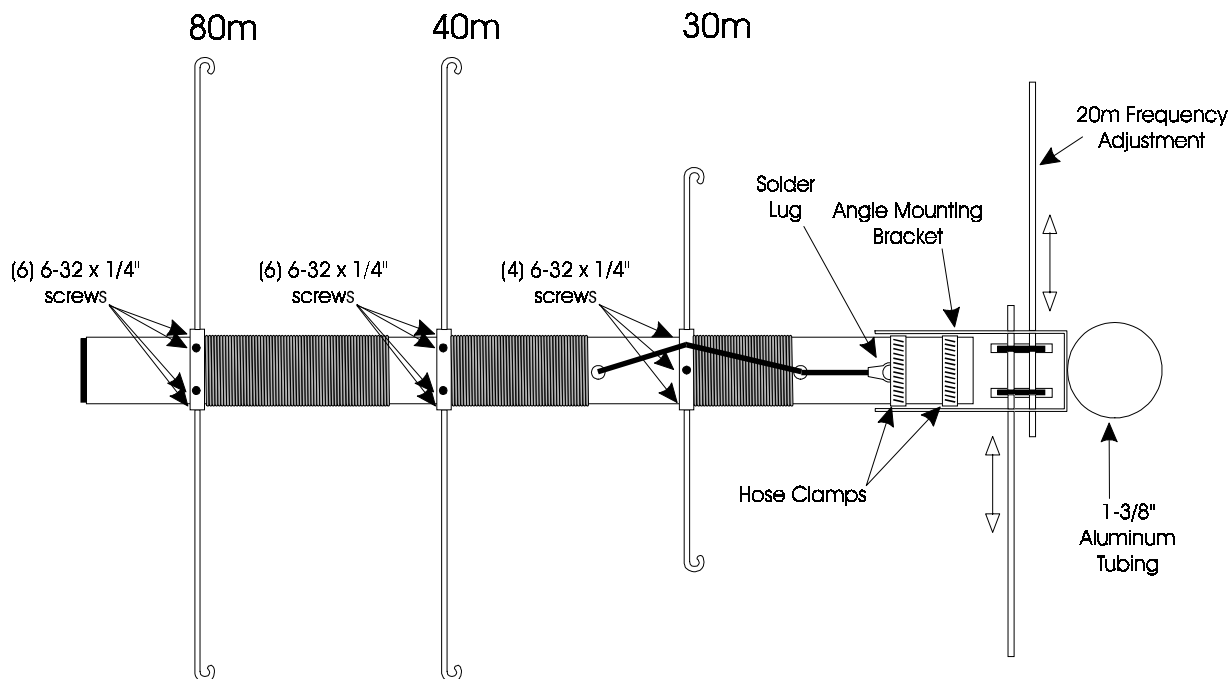

the fiberglass form, or the clamps. See Figure 10.

**Figure
9**

Locate the following parts:

Two 3/16" x 6' solid rods (A)

One 20 meter adjustable element clamp (C3)

One 6-32x 5/8" screw (B3)

46- Install the 20 meter adjustment rods (two 3/16" x 6' solid rods) using the 20 meter clamp that fits in the loading coil angle mount bracket. About 5' of rod should extend from each side. Tighten the 6-32 x 5/8" screw to lock the rods in place (*see Figure 10 on the following page*).

47- The antenna assembly is now complete, it can be tested using a transceiver on low power or with an SWR analyzer such as MFJ-249 or MFJ-259. It should be tuned *before* mounting it in any elevated location.

WARNING! You can be killed if the antenna, feed line, or the equipment used to install the antenna accidentally contacts any utility lines. Never install an antenna near power lines!

1. Be careful while climbing and carrying the antenna. It is heavy enough to cause you to lose your balance if it is handled too casually or if the counterpoise or the capacitance spokes are snagged on a gutter, ladder, tree limb, or any other object.
2. Mount the antenna high enough so that it is out of reach. The ends of the capacitance spokes, and other areas of the antenna, can cause eye injury, serious RF burns or both.
3. Make sure that the mast is sturdy enough to support 20 pounds of weight and a wind load of approximately 3 square feet.

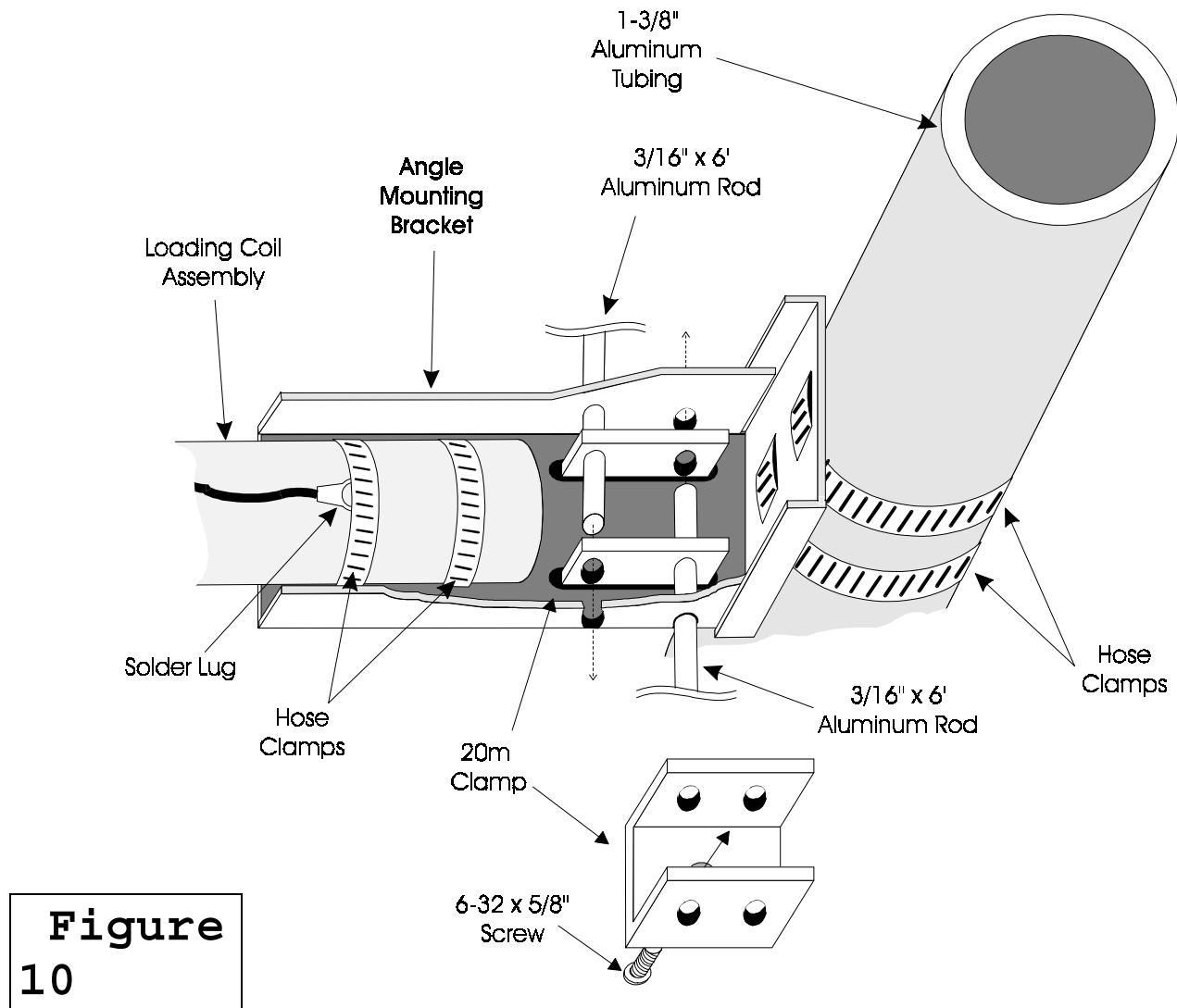

**Figure
10**

FREQUENCY AND SWR ADJUSTMENT

This antenna covers wide frequency ranges on higher bands, and narrower segments on lower frequency bands. The 40 meter band has the narrowest range of operation (approximately 40 KHz). The 80 meter band has a bandwidth of approximately 60 KHz and is the most sensitive to adjustments.

Please read the following hints:

1.) The normal resonant frequency of this antenna is at (or just below) the bottom of each amateur band. This allows the user to "trim" a small amount off the *inside end* of the capacitance spokes to raise the resonant frequency. Conversely, adding a longer capacitance spoke will lower the resonant frequency of a loading assembly. Spare spokes are included in case you need to lower the resonant frequency of the antenna.

2.) If you suspect the resonant frequency is lower than your equipment can detect, for example below 3.5 MHz, take one 80 meter spoke entirely off the antenna. Make another attempt to measure the resonant frequency. If you still can not find the resonant frequency, check another band. If none of these tests produce a good SWR on any frequency, substitute a 50 ohm load for the antenna to test the feedline. If the SWR checks good, you will have to double check the antenna assembly for shorts or opens at the feedpoint.

3.) If the antenna operates normally higher in the band after one spoke is removed, install all the spokes and trim one spoke in one inch steps until you find the resonant frequency is within the range of your equipment.

4.) Once you find the resonant frequency, the correct length of spoke length change to operate on the desired frequency change can be determined. Use the chart on the following page. When adjusting 80, 40, and 30 meters, adjust the antenna in order from the lowest band to the highest band.

CAUTION: Never trim the outer (rounded) end of the spokes. The sharp end that remains can be a safety hazard and the power handling of the antenna will be greatly reduced on some bands.

5.) The entire antenna must be accessible during initial tuning and testing. Any repair or adjustment of the antenna after it is installed on a tall support will be both difficult and time consuming.

**PLEASE READ THE FOLLOWING CAREFULLY BEFORE
TUNING THE ANTENNA!**

It is best to install the antenna on a short temporary mast or pipe located in a reasonably clear location for tuning. The simplest way to adjust the antenna is by mounting the antenna on a pipe that can be tilted over. This can be accomplished by mounting the antenna on a separate pipe from the temporary mast and using rope or long bolts to secure them.

The 20, 30, 40, and 80 meter adjustments generally do NOT affect the higher bands, so the 17 meter and higher frequency adjustments can be made with the loading coil and 20 meter adjustments removed. The loading adjustments at the bottom can be

re-installed after the higher bands are adjusted, if this is more convenient. *The lower bands can then be adjusted starting with 80 meters, since they can be reached from a step ladder.* The antenna must be mounted vertically with the base of the antenna around five or six feet above ground to make tests and adjustments accurate.

Caution:

The ground mounted adjustments remain fairly accurate only when the antenna is more than 30 feet from surrounding metallic objects or antennas. There may be a small upward shift in the resonant frequency of the antenna on 80, 40, and 30 meters if the antenna is relocated in location further from surrounding objects. This shift is greatest on 80 meters.

The SWR can be measured by using a transmitter and SWR bridge, or an SWR Analyzer. The best location to make SWR measurements is at the base of the antenna. If the measurements are not taken at the base of the antenna, the antenna must be fed with a reasonably short length of good quality 50 ohm coaxial cable. When using a transceiver and SWR meter, set the transceiver to the lowest power possible while making measurements.

TUNING THE ANTENNA ON LOW FREQUENCIES

Measure and record the frequency of lowest SWR occurs on each band. The MFJ-1798 is tuned for lowest SWR either at or below the lowest frequency of each HF band.

The following is a typical low frequency chart of initial measurements on a new antenna before tuning:

80 meter 1.2 : 1 @3.49 MHz 30 meter 1.2 : 1 @10.06 MHz
40 meter 1.2 : 1 @6.95 MHz

NOTE: If the resonant frequency is lower than your equipment can detect, completely remove one spoke. See the hints at the beginning of this section.

Trimming one spoke will result in the following frequency change:

80 m: 1" trimmed off a spoke moves the frequency up ***approximately*** 10 KHz
40 m: 1" trimmed off a spoke moves the frequency up ***approximately*** 20 KHz
30 m: 1" trimmed off a spoke moves the frequency up ***approximately*** 40 KHz

The lower frequencies (80 through 30 meters) can be adjusted while the antenna is mounted on a temporary mast five to six feet high. The antenna's resonant frequency may shift slightly higher

in frequency if (or when) the antenna is relocated. Moving the antenna higher, or farther from other objects, will usually cause an slight *increase* in the resonant frequency.

Caution: Always tune the lowest three frequency bands in order, starting with 80 meters.

Both 80 and 40 meters have narrow operating bandwidths. On 80 and 40 meters, the antenna will probably not cover the entire CW or phone band. The antenna must be tuned to a favorite "area" of 80 or 40 meters. An antenna tuner can be used to "stretch" the operating bandwidth on these bands. Avoid running the maximum rated power when operating with a non-tuned SWR over 3:1.

The following tuning procedure should be followed when adjusting 80, 40, and 30 meters.

Warning: Shortening the spokes from the looped end degrades safety and power handling capabilities!

TUNE 80 METERS FIRST

For 80 meters: Removing 1" from a single spoke will shift the resonant frequency up approximately 10 KHz.

Select a frequency 50 KHz below the desired operating frequency. Use this frequency as a target.

1- Measure the resonant frequency of the antenna. Determine the frequency shift required by subtracting the initial frequency from the desired frequency. Use the result to determine the proper amount to cut a spoke.

2- **If the calculated amount of element shortening exceeds 10"**, cut one inch from the inside end of all six spokes for each 10" calculated.

3- Return to step 1. Keep repeating these steps until the desired frequency is reached.

*Example: The antenna measured 3.47 MHz, the desired frequency is 3.95 MHz (less .05 MHz) for a difference of .43 MHz or 430 KHz. This would require the trimming of 43" from one spoke. Instead, cut 4.3 inches from **all six spokes** and measure the new resonant frequency. Assume the new resonant frequency is 3.82 MHz. A single spoke can now be trimmed 8" to adjust the antenna to resonance.*

TUNE 40 METERS NEXT (after 80 meters)

For 40 meters: Removing 1" from a single spoke will shift the resonant frequency up approximately 20 KHz.

Select a frequency 40 KHz below the desired operating frequency. Use this frequency as a target.

1- Measure the resonant frequency of the antenna. Determine the frequency shift required by subtracting the initial frequency from the desired frequency. Use the result to determine the proper amount to cut a spoke.

2- **If the calculated amount of element shortening exceeds 10"**, cut one inch from the inside end of all six spokes for each 10" calculated.

3- Return to step 1. Keep repeating these steps until done.

*Example: The antenna measured 6.95 MHz, the desired frequency is 7.25 MHz less .05 MHz (50 KHz) for a difference of .25 MHz or 250 KHz. This would require the trimming of 43" from one spoke. Instead, cut one 4.3 inch from **all six spokes** and measure the new resonant frequency. Assume the new resonant frequency is 3.82 MHz. A single spoke can now be trimmed 8" to adjust the antenna to resonance.*

TUNE 30 METERS LAST

*For 30 meters: Removing 1" from a single spoke will shift the resonant frequency up **approximately** 40 KHz.*

Select a frequency 20 KHz below the desired operating frequency. Use this frequency as a target.

1- Measure the resonant frequency of the antenna. Determine the frequency shift required by subtracting the initial frequency from the desired frequency. Use the result to determine the proper amount to cut a spoke.

2- **If the calculated amount of element shortening exceeds 8"**, cut one inch from the inside end of all four spokes for each 8" calculated.

3- Return to step 1. Keep repeating these steps until done.

*Example: The antenna measured 9.95 MHz, the desired frequency is 10.15 MHz less .02 MHz (20 KHz) for a difference of .18 MHz or 180 KHz. This would require the trimming of 4.5" from one spoke. Cut 4.5 inches from **one spoke** and measure the new resonant frequency. Assume the new resonant frequency is 10.1 MHz. You would only have to shorten a spoke 3/4 inch to be done.*

TUNING 20 METERS

Tuning the 20m band is done almost the same way, except there is much less interaction in the adjustments with the other band groups. Loosen the 6-32 screw up that applies tension to the 20 meter tuning rods. Sliding the 20 meter capacitor rods in (decreasing the rods total length) will increase the frequency. Sliding the 20 meter tuning rods out (increasing the rods length) will decrease the frequency (*refer to Figure 8 on page 18*).

TUNING 17 THROUGH 2 METERS

Frequency adjustments on 17 through 2 meters are accomplished by shortening or lengthening the various stub elements. Since the counterpoise is electrically large on these bands, and the elements are full size, the bandwidths are fairly broad. This makes tuning fairly non-critical. There is also very little interaction between adjacent bands or with the lower bands.

There are two methods of tuning the stubs on these bands. One method involves loosening the nuts at the threaded end of the stub and moving the stub up or down in the counterpoise support plate, the other would involve cutting the ends of the rods with a large wire or small bolt cutter.

While cutting the stub is more convenient, care must be exercised to avoid removing too much material. For this reason, we suggest removing only enough material to move the antenna slightly on the low side of the desired resonant frequency.

TUNING 2 METERS.

2 meters can be adjusted with the antenna in *nearly any position*, including lying down. The *only* restriction is that the 2 meter element must be at least 3 feet above the ground and away from other objects.

TUNING 6 METERS

Six meters shares a common stub with 17 meters. There is no separate six meter adjustment. If you would like to optimize six meters for the best low angle performance, one of the four stubs can be cut to approximately five feet in length and then trimmed for lowest SWR at the operating frequency.

TUNING 10 THROUGH 17 METERS

All these bands are tuned by lengthening or shortening the threaded portion of the stubs, or by trimming the stubs at the bottom. The adjustments are very coarse. If frequency is still too low with the stub extension at minimum, the unthreaded ends of the stubs can be trimmed.

Shortening the stubs length raises the operating frequency, while extending the stub length lowers the operating frequency.

Note: Tuning the 17 meter stub affects the 6 meter band.

Once the antenna tuning is completed and double checked, the antenna can be moved to a permanent location. Although performance will be better if the antenna is elevated, the performance will probably still be acceptable with heights as low as six feet 6'.

The special TOP FEEDING TECHNOLOGY (TFT) allows the major radiating portion of the antenna to be at least 16' above ground level, even with the base at ground level.

Warning: Always keep antenna away from any power line, Also keep antenna away from reach of adult and children. Antenna spokes have very high voltage on them, it can be lethal if touched while transmitting.

Technical Assistance

If you have any questions that the manual does not answer, please contact MFJ Enterprises. You may call MFJ toll-free at 1-800-647-TECH (8324), FAX 1-601-323-6551, or TELEX 53 4590 MFJ STKV. Outside the continental USA please call 601-323-5869. Please have the model number, date of purchase, this manual and all additional information you can supply close by the telephone. This will help with any questions the technicians may have.

You can also send written correspondence to MFJ Enterprises INC., PO Box 494, Mississippi State, MS 39762. Send a complete description of your problem, an explanation of exactly how you are using your unit and a complete description of your station.

If you have any helpful suggestions, or find any errors in this manual, please drop us a note. Direct your comments to Attn.: Product Engineering at the above address. We appreciate your assistance and thank you for purchasing our products.

FULL 12 MONTH WARRANTY

MFJ Enterprises, Inc. warrants to the original owner of this product, if manufactured by MFJ Enterprises, Inc. and purchased from an authorized dealer or directly from MFJ Enterprises, Inc. to be free from defects in material and workmanship for a period of 12 months from date of purchase provided the following terms of this warranty are satisfied.

1. The purchaser must retain the dated proof-of-purchase (bill of sale, canceled check, credit card or money order receipt, etc.) describing the product to establish the validity of the warranty claim and submit the original or machine reproduction of such proof of purchase to MFJ Enterprises, Inc. at the time of warranty service. MFJ Enterprises, Inc. shall have the discretion to deny warranty without dated proof-of-purchase. Any evidence of alteration, erasure, or forgery shall be cause to void any and all warranty terms immediately.
2. MFJ Enterprises, Inc. agrees to repair or replace at MFJ's option without charge to the original owner any defective product provided the product is returned postage prepaid to MFJ Enterprises, Inc. with a personal check, cashiers check, or money order for **\$7.00** covering postage and handling.
3. MFJ Enterprises, Inc. will supply replacement parts free of charge for any MFJ product under warranty upon request. A dated proof of purchase and a **\$5.00** personal check, cashiers check, or money order must be provided to cover postage and handling.
4. This warranty is **NOT** void for owners who attempt to repair defective units. Technical consultation is available by calling (601) 323-5869.
5. This warranty does not apply to kits sold by or manufactured by MFJ Enterprises, Inc.
6. Wired and tested PC board products are covered by this warranty provided **only the wired and tested PC board product is returned**. Wired and tested PC boards installed in the owner's cabinet or connected to switches, jacks, or cables, etc. sent to MFJ Enterprises, Inc. will be returned at the owner's expense unrepaired.
7. Under no circumstances is MFJ Enterprises, Inc. liable for consequential damages to person or property by the use of any MFJ products.
8. **Out-of-Warranty Service:** MFJ Enterprises, Inc. will repair any out-of-warranty product provided the unit is shipped prepaid. All repaired units will be shipped COD to the owner. Repair charges will be added to the COD fee unless other arrangements are made.
9. This warranty is given in lieu of any other warranty expressed or implied.

10. MFJ Enterprises, Inc. reserves the right to make changes or improvements in design or manufacture without incurring any obligation to install such changes upon any of the products previously manufactured.
11. All MFJ products to be serviced in-warranty or out-of-warranty should be addressed to **MFJ Enterprises, Inc., 921A Louisville Road, Starkville, Mississippi 39759, USA** and must be accompanied by a letter describing the problem in detail along with a copy of your dated proof-of-purchase.
12. This warranty gives you specific rights, and you may also have other rights which vary from state to state.