

TABLE OF CONTENTS

Introduction

1.0 Powering the MFJ-1275

2.0 Connecting the MFJ-1275

3.0 Microphone and Radio Connections

 3.1 Internal Header and Jumper Connection Description

 3.2 Programming Internal Jumpers

4.0 Rear Panel Connections

 4.1 Computer RS-232 port

 4.2 Radio

 4.3 Computer

 4.4 Ground

5.0 Operating Suggestions

 5.1 Placement of this Unit

 5.2 Hum, Squeals, and Distortion

 5.3 Operating Adjustments

 5.4 Monitoring Receiver (SSTV, Voice Keyer)

6.0 Trouble Shooting Guide

7.0 Technical Assistance

8.0 Schematic

INTRODUCTION

Thank you for purchasing the MFJ-1275 (or modular 1275M) *Sound Card Radio Interface*. The MFJ-1275 was designed for use in all sound card to radio applications. Great care was taken to make sure hum, noise, and distortion is minimized or eliminated, insuring the best possible signal from your equipment.

Before attempting to use the MFJ-1275, please read section 3.0. This section contains important information when interfacing MFJ-1275 with your transceiver. We'll start with a brief introduction to the special features that make your *Sound Card Radio Interface* an important addition to any station with a computer.

MFJ-1275(1275M) Features:

Serial Port: This port allows the computer to control the push-to-talk of your radio, and the microphone push-to-talk switch to override and/or interrupt your computer's transmission.

Microphone/Radio plug-in jumpers: Internal jumpers program microphone wiring for any brand or model of radio with the appropriate 8-pin connector. No need to solder tiny plugs and wires or purchase adapters.

PTT Message Interrupt/Stop: Microphone PTT (push-to-talk) switch automatically halts outgoing messages when using software that allows external com-port interrupts. Even if software does not allow interrupts, you can still hold the microphone PTT to stop digital transmissions and transmit microphone audio.

Radio/Speaker-Computer/Speaker switching: Transfers audio lines with a touch of the ON/BYPASS switch. No need to move cables every time you change use of the computer or radio. NOTE: Requires you use external speaker on radio.

Off-Air Recording: Capture signals from your receiver's audio jack for review or replay, or use with spectrum analyzer programs.

RFI Proof Circuitry: RF suppression and line isolation virtually eliminates RF feedback, hum, and distortion. Isolating transformer prevents audio ground loops.

Level controls: Two level controls, one for transmitter drive and one for receiver-to-sound card drive level. No need to adjust microphone gain or sound card level settings every time you change modes.

Stereo or Mono Audio input: A front-panel switch selects left, right, or both sound card audio output channels.

Rugged Construction: Rugged all aluminum cabinet and surface-mount construction means mechanical and electrical survivability.

1.0 POWERING THE MFJ-1275

External Power: Use any well filtered power source capable of supplying 12-15 Vdc @100 mA (minimum operating voltage is 10 Vdc under full load, sources exceeding 16 Vdc may permanently damage this product). The Sound Card Radio Interface's external power jack accepts a standard 2.1mm coaxial power plug (spares are available from Radio Shack). *The power plug's center pin must be positive (+) and ground-isolated.* The outer shell is negative (-) and may be grounded or floated at the supply. When connecting to a high current (more than one ampere) supply, we strongly recommend fuse protecting both positive and negative supply leads with ½ ampere to 1 ampere fast-blow fuses.

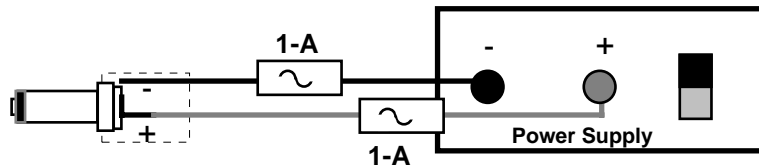

WARNING: Never insert the power plug with power applied—an accidental short from (+) to chassis ground may result. Also, never allow the MFJ-1275/1275M supply voltage to exceed 16 Vdc. Connections to high current power sources must be fuse protected!

MFJ-1312B Power Supply: The MFJ-1312B wall adapter is also suitable for powering your Sound Card Radio Interface. It comes with the correct 2.1mm power plug installed, and is available directly from MFJ Enterprises, Inc. or through your local MFJ dealer.

2.0 CONNECTING THE MFJ-1275

FRONT PANEL:

MICROPHONE	Accepts standard 8-pin microphone plug (8-pin modular for the MFJ-1275M)
INPUT	Selects left, both, or right sound card audio channel
MANUAL/VOX	Selects PTT control from COM port or VOX operation
ON/BYPASS	Selects computer audio and control (ON) or normal operation of computer and radio (BYPASS)
XMIT	Illuminates when computer transmitting or ready to transmit (VOX) with audio input
POWER	Illuminates when unit is in ON mode

REAR PANEL:

POWER Requires 12-15 Vdc @ 100mA (16 volt absolute maximum)

COMPUTER RS-232 DB-9 female serial (COM port) connection

RADIO

TO EXT SPKR 3.5mm mono jack connects to station loudspeaker or other audio accessories normally connected to radio speaker jack.

TO RADIO MIC 3.5mm mono jack connects to external speaker output of radio

COMPUTER

TO SOUND CARD AUDIO IN 3.5mm mono jack connects to sound card input

TO EXT SPKR 3.5mm stereo jack connects to computer speaker

FROM SOUND CARD AUDIO OUT 3.5mm stereo jack connects to sound card output

GROUND Ground terminal to station's ground buss (see section 4.4)

3.0 MICROPHONE AND RADIO CONNECTIONS

Different manufacturers (and sometimes different radios from the same manufacturer) wire the same style connectors differently. The MFJ-1275 and 1275M have internal headers that use small moveable jumpers. The MFJ-1275 uses common round 8-pin microphone connectors found on most transceivers. The MFJ-1275M comes with a modular microphone jack (like telephones might use).

Internal jumpers are used to program connections for any radio that connects to the prewired connectors. This feature eliminates the need for soldering jacks or purchasing adapter cables. **The MFJ-1275/1275M must be configured using the internal jumpers before use.** See section 3.1 and 3.2.

The microphone/radio setup procedure requires a few minutes of time, but you must have a manual for your radio.

IMPORTANT INFORMATION CONCERNING THE MFJ-1275M

The MIC pins on the Radio Shack and Icom radios are numbered 1 through 8, from left to right. Whereas, the Yaesu and Kenwood radio MIC pins are numbered 1 through 8, from right to left. The MFJ-1275M numbering scheme matches the Kenwood and Yaesu scheme.

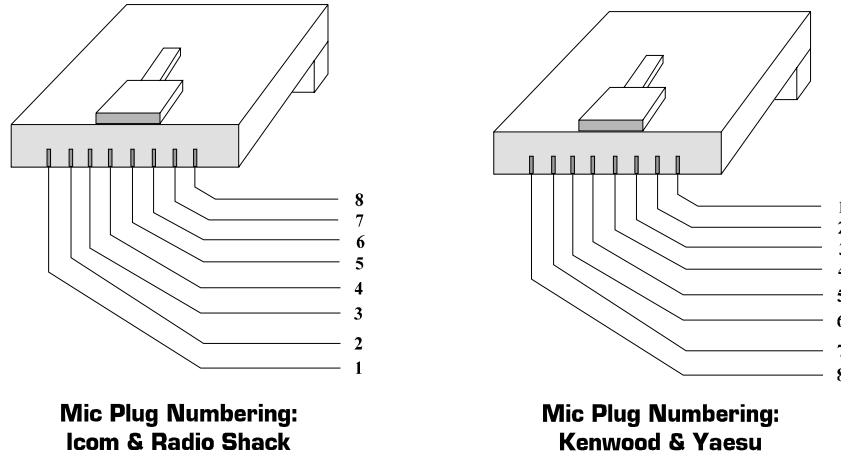

If you want to use the MFJ-1272M with an Icom or Radio Shack transceiver, then all jumper designations need to be thought of in reverse order. This is due to the numbering scheme on the Radio Shack and Icom microphones.

3.1 INTERNAL HEADER AND JUMPER CONNECTION DESCRIPTION

The jumpers in this unit are grouped by connection type, with all eight microphone pins in a row. The connection blocks are:

- HD1** Chassis ground
- HD2** Audio ground (NOT the same as chassis ground)
- HD3** Pass through connection (generally must also be pass-through connected)
- HD4** Audio from microphone
- HD5** PTT line to radio
- HD6** PTT from microphone
- HD7** Microphone audio output to radio

There are eight rows of jumpers (16 pins) in each header. Each pin, starting from the rear of the unit, represents pins one through eight of the microphone connectors.

HD1 Chassis Ground

This header makes a connection to chassis ground. The chassis ground is normally *not* connected to the microphone ground except in the radio itself.

WARNING: If the chassis is connected to the microphone outside the radio, the result is usually low-level audio hum on the transmitted signal.

HD2 Audio Ground

This header connects to the microphone audio ground. The pin selected here should match the *audio* ground lead on the radio and microphone. This ground is normally *not* connected to the chassis ground except in the radio itself.

WARNING: If the audio ground is connected to a chassis someplace outside the radio, the result can be audio hum or distortion.

HD3 Pass-through Connection

The pass-through connection should have jumpers in all connections except leads used by microphone “hot” audio (HD4, HD7) and push-to-talk lines (HD5, HD6).

The microphone *ground* leads, both PTT and audio *grounds*, should remain jumpered at this header even if they are connected to ground at either HD1 or HD2.

HD4 Audio from Microphone

This header is for the microphone’s audio output lead. This pin should match the microphone’s “hot” audio lead. The pin selected here should also be selected at HD7.

HD5 PTT to Radio

This header is for the radio’s PTT (push-to-talk) lead. This pin should match the radio’s “hot” PTT lead. The pin selected here should also be selected at HD6.

HD6 PTT From Microphone

This header is for the radio’s PTT (push-to-talk) lead. This pin should match the microphone’s “hot” audio lead. The pin selected here should also be selected at HD5.

HD7 Audio to Radio Microphone

This header is for the microphone’s audio output lead. This pin should match the radio’s “hot” audio input lead from the microphone. The pin selected here should also be selected at HD4.

3.2 PROGRAMMING INTERNAL JUMPERS

Begin by removing screws from the sides of the cabinet. Lift the cover off, and notice the group of pins and black jumpers on the left side (front view) behind the microphone connector and in front of the microphone output wire. Notice the pins start at the back and are labeled 1 through 8 before repeating at the next header group.

Place jumper at the pins where the X's are:

Table 1. Yaesu FT-1000 series

Pin	HD1 chas/ptt	HD2 mic gnd	HD3 pass	HD4 mic aud	HD5 rad ptt	HD6 mic ptt	HD7 rad aud
1			X				
2			X				
2			X				
4			X				
5	X		X				
6					X	X	
7		X	X				
8				X			X

To configure your interface, look at the radio's manual. Find the page that shows the microphone wiring. This is a sample Yaesu-style connection.

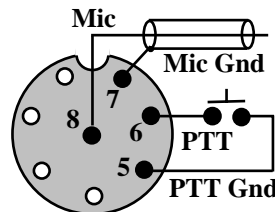

Yaesu Mic Jack Pin-out, Front View

If you compare table 1 to this connector, you'll see it is laid out for this radio.

Look at the microphone wiring diagram and connect the PTT and microphone leads as described in section 3.1. We've provided a blank chart below for you to fill in. **Remember header 4 and 7, as well as 5 and 6, are the same. A pass connection belongs on every other lead, including connections also used for grounds.**

Using the following wiring chart:

- 1.) **Never ground the microphone ground to the chassis ground**
- 2.) **HD4 and 7 are always the same**
- 3.) **HD5 and 6 are always the same**
- 4.) **HD3 always has a jumper except were HD4,5,6 and 7 have one**

Pin	HD1 chas/ptt	HD2 mic gnd	HD3 pass	HD4 mic aud	HD5 rad ptt	HD6 mic ptt	HD7 rad aud
1							
2							
2							
4							
5							
6							
7							
8							

4.0 REAR PANEL CONNECTIONS

The rear panel has 5 audio jacks and one computer port.

4.1 COMPUTER RS-232 PORT

The **COMPUTER RS-232** port is a standard female DB-9 connector. It should connect to an active COM port on your computer. This connection allows the computer to watch the PTT line from your microphone, and the computer to control the transmitter PTT line.

4.2 RADIO

FROM AUDIO OUT: This 3.5mm monaural jack connects to your radio's external speaker output jack.

Always run the receiver at normal listening volume before switching to digital modes. Internal potentiometer R31 sets the drive level from the radio receiver to the sound card. It is the screwdriver adjustable potentiometer closest to the rear of the unit. A hole is provided in the cover so the pot can be adjusted without removing the cover. Use a small flat-blade screwdriver, and be careful to not break the potentiometer.

TO EXT SPKR: This 3.5mm monaural jack is for the external speaker normally connected to the radio. This jack is connected to the radio's external speaker output when the front panel **ON/BYPASS** switch is out, and is disconnected the **ON/BYPASS** switch is in.

4.3 COMPUTER

TO SOUND CARD AUDIO IN: This 3.5mm monaural jack is the sound card audio input connection. You can use either the microphone or line input of the sound card. This jack is not connected to the radio's audio output when the **ON/BYPASS** switch is out (BYPASS). It connects the sound card input to the radio's audio output when the **ON/BYPASS** switch is ON.

Note: If you use the microphone input, you'll want to disable any extra gain if provided by the sound card and accessible in the software. This function is normal available in the "Advanced" menu of sound card software. Be sure to set up the input for mono operation of the input, if applicable.

TO EXT SPKR: This 3.5mm stereo jack is the output connection to the computer's speaker system. This jack is connected to the computer's audio output when the **ON/BYPASS** switch is out (BYPASS). It is disconnected the **ON/BYPASS** switch is ON (In).

FROM SOUND CARD AUDIO OUT: This 3.5mm stereo jack connects to the computer's audio output. This jack is connected to the computer's audio output when the **ON/BYPASS** switch is out (BYPASS). It is disconnected the **ON/BYPASS** switch is in (ON).

4.4 GND

We have provided a ground connection post in case you have RF problems or hum. In many cases, this connection will not be needed. If you notice hum or noise on any audio lines, then connect this post (with the shortest possible connection) to the ground post on your radio.

5.0 OPERATING SUGGESTIONS

5.1 PLACEMENT OF THIS UNIT

We recommend placing this unit as close to the radio and computer as possible. Do not place this unit within one foot of power transformers, video monitors, or anything that emits strong varying magnetic fields. If you locate this unit near a monitor, the sweep circuits can introduce hum and noise into your signal. If there is a powerline operated transformer within several inches and if it has flux leakage, 60-cycle hum can be introduced into your stations audio systems.

5.2 HUM, SQUEALS, AND DISTORTION

When different pieces of equipment are interconnected, unwanted hum and audio distortion or oscillations may result. RF feedback or an audio system loop of some kind may cause this condition.

To eliminate RF feedback as the cause, replace the antenna with a dummy load. If the problem still appears while transmitting at full power level, it is probably caused by a ground loop. If the problem disappears, it is almost certainly RF related. Make sure your station ground is good, and you have followed suggestions found in reliable sources like the ARRL Handbook.

If the problem still occurs even while transmitting on a dummy load, be sure you have placed the microphone wiring jumpers correctly as outlined in section 3 of this manual. Make absolutely sure the microphone ground connection has continuity through the entire system, and that it is NOT connected to any other grounds or chassis' except inside the radio.

Be sure you have not created a problem with improper configuration of the sound card or radio. Try turning the radio's monitor OFF when working digital, in case audio is looping from the monitor back through the sound card to the transmitter's input.

5.3 OPERATING ADJUSTMENTS

The most common problem with digital modes is improper system level. Even at best, digital modes have limited dynamic range (ratio of strongest undesired signal tolerated to weakest signal copyable) compared to modes that “fit” the filters in the transmitter and receiver. This is mainly because the entire system affects bandwidth.

Transmitting

When transmitting, it is extremely important to have levels correct. If you overdrive the input of your transceiver, your signal may interfere with others. Such problems do not always show up on spectrum or IMD displays, and if they do many people don't recognize them. Excessive level into the radio can aggravate harmonic distortion (this does not register on IMD readings), causing you to transmit on multiple frequencies. For example if you are on PSK and using a 1,000 hertz receiving and transmitting sound card frequency, you will also have some signal level at 2,000 hertz and every other multiple of 1,000 Hz.

The system depends entirely on low distortion in the sound card and the transmitter, as well as the filter in the transmitter, to limit the level of these unwanted signals.

If audio level from the sound card or interface is too low, the ratio of signal to hum and noise will be reduced.

The best way to check for proper transmission is to listen to your own signal on a separate receiver with a narrow filter, taking care to not overload the receiver. If you can't do that, the best general guideline is to use normal microphone gain settings and approximately half volume on the sound card “Volume” settings. Adjust the transmitter level control (R18) in the MFJ-1275 for normal transmitter drive (just at the start of ALC action) and use the microphone gain on the transmitter (or sound card volume) for fine adjustment. It is always a good idea to have someone listen to your signal when the band is empty, signals are strong, and noise is very low. They should look carefully for spurious signals, noise, and hum.

When transmitting on modes like MFSK and PSK, try to use a frequency setting of more than 1400 Hz and less than 2200 Hz. This will allow the transmitter's SSB filter to suppress any unwanted harmonics from the audio system driving the transmitter.

Receiving

Use normal receiver volume setting, and adjust the sound card microphone level (make sure any extra gain options are off) to approximately half scale. Adjust the receiver level control (R31) in the MFJ-1275 for normal display operation.

Remember it is sometimes necessary to select the narrowest filter possible in the receiver, rather than depending on the computer to filter out strong unwanted stations. Many transceivers allow selection of narrower filters while operating SSB, or include passband-tuning controls. If you have trouble with a strong station nearby causing you to lose the desired signal, try more selectivity or using a notch filter.

5.4 MONITORING RECEIVER (SSTV, VOICE KEYS)

Certain modes may require listening to receiver audio. In cases where it is not necessary for the radio's speaker output to “talk to” the sound card when receiving (i.e. voice-keyer operation), you can simply unplug the radio speaker lead and connect it directly to the radio's speaker output. The speaker output will not route through the interface unit.

Other modes, like SSTV, require alternating between digital and normal audio modes. The best way to accomplish this is by turning **OPERATE/BYPASS** switch off when receiving voice, and turning it to **OPERATE** when transmitting and receiving SSTV transmissions.

6.0 TROUBLE SHOOTING GUIDE

Sound Card Radio Interface Won't Power Up: Check power connections and cables. Also, check the voltage and polarity of your power source--it must be capable of providing 12-15 Vdc @ 100 mA.

Transmitting

Station Microphone PTT Function won't work: Check internal microphone PTT jumpers. Read section 3 of this manual. Do the jumpers match the type of transceiver you are using?

Station Microphone has no audio: Check internal microphone PTT jumpers. Read section 3 of this manual. Do the jumpers match the type of transceiver and microphone you have?

Low or Excessive Transmit Level on digital: Has the *Transmit Level Control R18* been set for the transmitter currently in use? Does R18 need adjusted to bring the output level within the transceiver's limits? See section 5.

Sound Card Radio Interface Won't Activate PTT line on Playback: Check *XMIT* switch position.

PTT Switch Fails to Halt Message Playback: Check com-port configuration. Does your software include this function?

Hum and Distortion: See section 5.0 and check wiring of jumpers (section 3). Also check to be sure correct connections have been made with jumpers.

Receiving

Poor print or copy on good signals, distorted digital recordings: Are levels from your receiver too high or too low, is potentiometer R31 adjusted correctly? (see section 4.2) Are sound card settings configured correctly? See section 5.

7.0 TECHNICAL ASSISTANCE

If you have any problem with this unit first check the appropriate section of this manual. If the manual does not reference your problem or your problem is not solved by reading the manual, you may call *MFJ Technical Service* at **662-323-0549** or the *MFJ Factory* at **662-323-5869**. You will be best helped if you have your unit, manual and all information on your station handy so you can answer any questions the technicians may ask.

You can also send questions by mail to MFJ Enterprises, Inc., 300 Industrial Park Road, Starkville, MS 39759; by Facsimile (FAX) to 662-323-6551; or by email to techinfo@mfjenterprises.com. Send a complete description of your problem, an explanation of exactly how you are using your unit, and a complete description of your station. Remember this is the slowest and most unreliable way of asking complicated questions. Talking to a person is much better.

8.0 SCHEMATIC

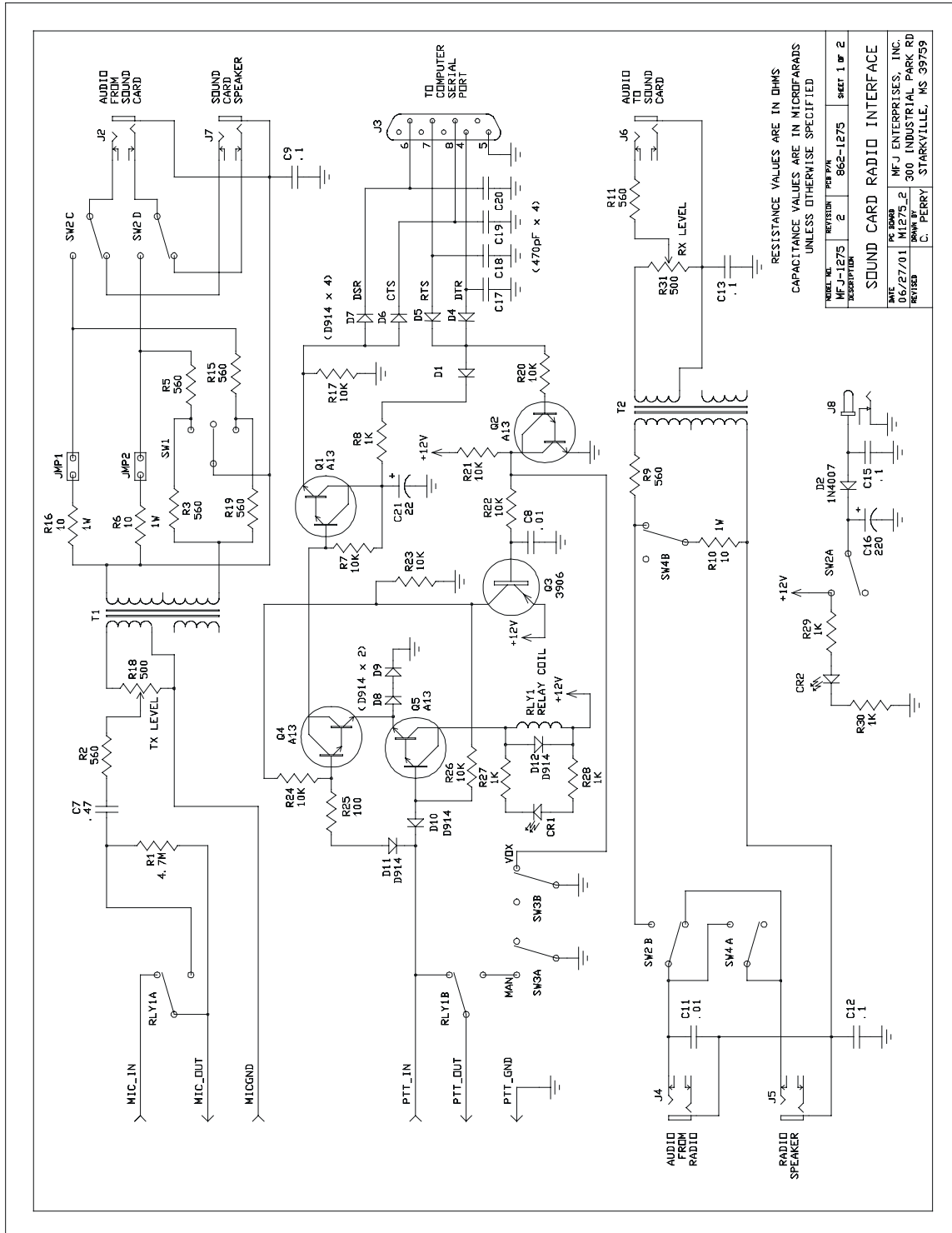

RESISTANCE VALUES ARE IN OHMS
CAPACITANCE VALUES ARE IN MICROFARADS
UNLESS OTHERWISE SPECIFIED

PC BOARD DESCRIPTION	MFJ-1275	REV. 2	862-1275	SHEET 1 OF 2
DATE	06/27/01	PC BOARD	MFJ ENTERPRISES, INC.	
REVISED		DRAWN BY	11275-2	
			300 INDUSTRIAL PARK RD	
			C. PERRY, STARKVILLE, MS 39759	

