



## **PV CHARGE CONTROLLER**

### **USER MANUAL**

**SBC-2106 / 2106L**

## I. INTRODUCTION

The SBC-2106 PV Charge Controller is a sealed controller using advanced PWM charging technology. It is designed for use with all types of PV panel/system and Seal or Wet Type Lead Acid Batteries.

## II. SAFETY PRECAUTIONS

1. **DO NOT** exceed the voltage or current ratings of the controller.  
Use only with a 12-volt battery.
2. **DO NOT SHORT CIRCUIT** the solar array while connected to the controller.  
This will DAMAGE the controller.
3. **DO NOT SHORT CIRCUIT** the load terminal (or WHITE wire to any black wire) when battery or PV panel is connected. This will DAMAGE the controller.
4. The negative system conductor should be properly grounded for most effective lightning protection.
5. **WARNING** - Be very careful when working with batteries. Lead acid batteries can generate explosive gases, and short circuits can draw thousands of amps from the battery. Read all instructions provided with the battery.

## III. OPERATION AND FUNCTIONS

1. 100% SOLID STATE: All power switching is done with MOSFET. No mechanical relays are used.
2. BATTERY CHARGE REGULATION: the controller uses PWM charge for constant voltage charging. A true 0 to 100% PWM duty cycle is designed for maximum and safe charging.
3. The controller prevents the battery from discharging through the solar array at night. There is no need to install any blocking diode for this purpose.
4. This controller provides Night Light Load function. The Load will be turned on at night (PV voltage  $\leq 3.5V$ ) and will be turned off in morning (PV voltage  $\geq 5V$ ).

## IV. CONTROL

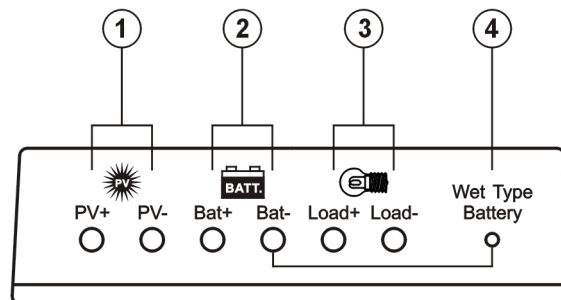

- (1) PV Terminal
- (2) Battery Terminal
- (3) Load Terminal(ONLY available in SBC-2106L – see rating label)
- (4) Sealed/Wet Type Battery Selection Blue Color Wire

## IV. INSTALLATION

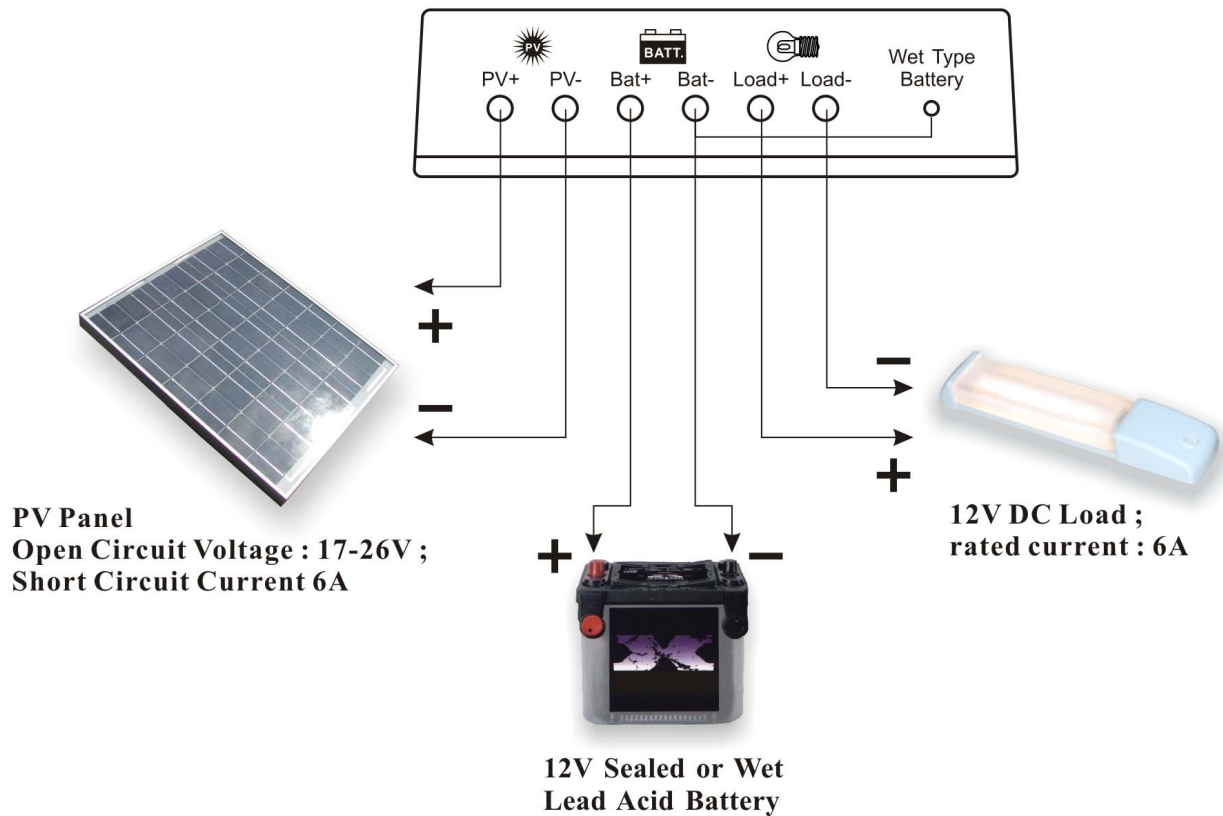

\* SBC-2106 User, please ignore the connection of load terminals.

1. Connect the **Bat- BLACK** wire to the battery's negative terminal.
2. If you use Wet-Type Lead Acid Battery, connect the blue color wire(4) to the battery's negative black wire.  
If you do not use Wet-type lead acid battery, keep the blue cable insulated and isolated.
3. Connect the **Bat+ RED** to the battery's positive terminal.
4. Connect the Solar array using the PV BLACK wire and the YELLOW PV positive wire.  
Be very careful not to short circuit the solar array, or the controller will be damaged.
5. The controller prevents reverse current leakage at night, so a blocking diode is not required in the system.
6. **For SBC-2106L User ONLY:**  
Connect the load (DC Lamp) using the Load BLACK wire and WHITE load positive wire.  
Be very careful not to short circuit the load terminal, the controller will be damaged.
7. A negative earth ground at the battery is recommended for most effective lightning protection.
8. The controller is splash proof, so it can be mounted outdoors in a vertical position.  
Do not expose to ambient temperature above 60°C.

## V. SPECIFICATIONS

Model Number	SBC-2106	SBC-2106L
Battery System Voltage	12V	
Max. PV Open Circuit Voltage	26V	
Max PV Short Circuit Current	6A	
PWM Setpoint	Sealed Type Battery Setting: $14.3V \pm 0.1V$ Wet Type Battery Setting: $14.8V \pm 0.1V$	
Min. Operating Voltage	3V	
Rated Charging Current	6A	
Max. Load Current (1 min.)	8A	
Max. Charging Current (5 min.)	8A	
Rated Load Current	6A	
PV voltage while Load Turn ON	SBC-2106 does not have load terminals	$\leq 3.5V$
PV voltage while Load Turn OFF		$\geq 5 + 0.2V$
Low Battery Shutdown for load		$\leq 11.5V \pm 0.2V$
Low Battery Recover for load		$\geq 12.5V \pm 0.2V$
Ambient Temperature Range	- 40 ~ +60 °C	
Relative Humidity	100%	
Approvals	EN 55022 / EN 61000 / FCC PART15 Subpart B Class B	
Dimensions ( L x W x H )	97 x 46 x 20.5 mm	
Weight	103g	

**All values are based on the Standard ambient Temperature 25°C and Pressure 0.1Mpa.**